

ORIGIN® 2017

Graphing & Analysis

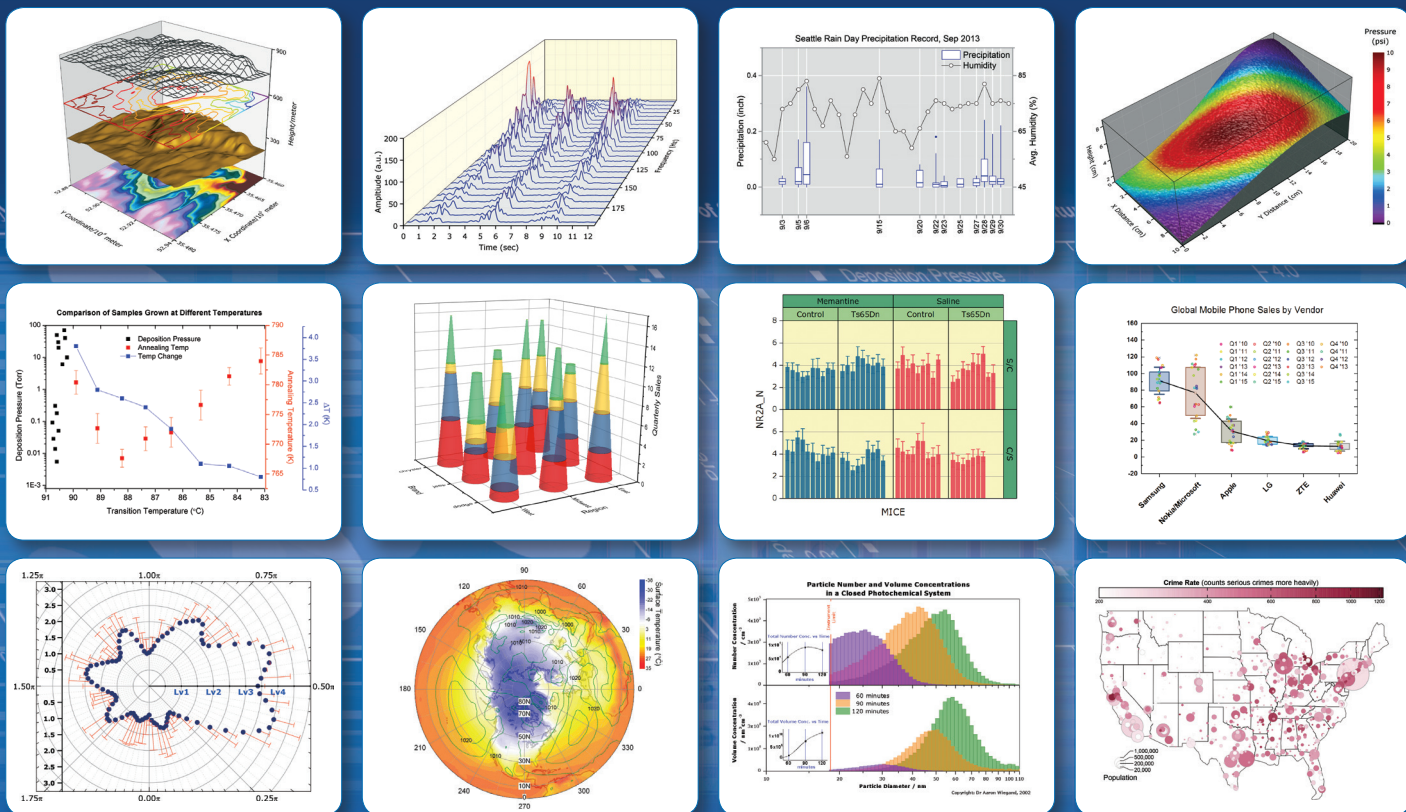

Introduction to Origin and OriginPro	2	Handling Repetitive Tasks	28-31
What's New in Origin 2017.	4-5	Custom Reports	32
2D Graphing	6-11	Publishing	33
3D Graphing	12	Working with Excel®, MATLAB® Connectivity	34
Database Access	14	LabVIEW™ Connectivity	35
Data Processing	16	Programming.	36-39
Gadgets	18	User Case Studies	40
Apps in Origin	19	Comparison of Origin and OriginPro	42
Curve Fitting	20	Key Features by Version.	44
Peak Analysis.	22	Licensing	48
Signal Processing.	24	Product Support	50
Statistics	26	About OriginLab	51

25+ years serving the scientific and engineering community.

ORIGIN[®] From Data to Results

Origin is a user-friendly and easy-to-learn software application that provides powerful data analysis and publication-quality graphing capabilities tailored to the needs of scientists and engineers.

OriginPro offers all of the features of Origin plus extended analysis tools for Peak Fitting, Surface Fitting, Statistics, Signal Processing, and Image Handling.

Origin allows you to customize operations such as importing, graphing and analysis, all from the GUI. Origin also automatically updates all graphs, analysis results and reports when data or parameters change. This allows for batch analysis of multiple files or datasets without the need for programming.

Import, Query, Connect

Import data from ASCII, CSV, Excel[®] or Third-Party data files.

Query database, or send data and commands to Origin from client applications such as LabVIEW[™], MATLAB[®], or Excel.

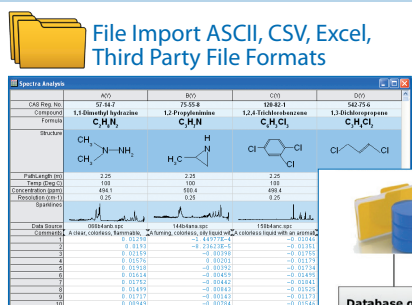

File Import ASCII, CSV, Excel, Third Party File Formats

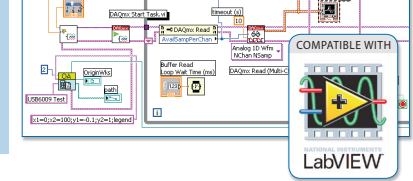

LabVIEW[™] Sub VIs

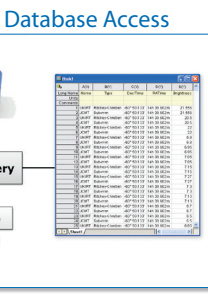

Database Access



Multisheet Workbook with Metadata Label rows and Sparklines

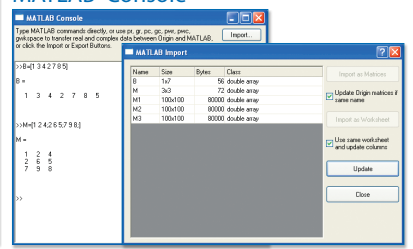

MATLAB[®] Console

Graph, Explore

Create and customize publication quality graphs with ease. Save customizations as a template or Theme for repeat use. Explore data graphically including easy zoom and scroll within layers.

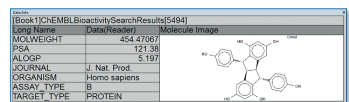

The Data Info tool lets you explore data from your graph, including display of related information from other columns

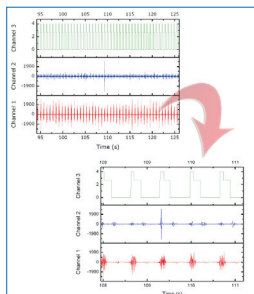

Explore data graphically including easy zoom and scroll

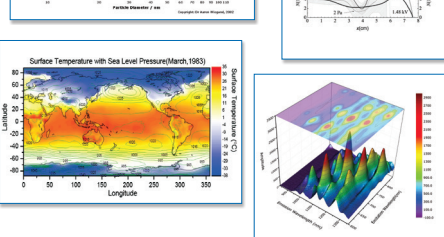

Create publication-quality 2D and 3D graphs using built-in or custom templates

"Yet again Origin and OriginPro upholds its foremost status as the best purposeful and all-embracing data analysis and graphing software on the market. Although other software packages exist, few are as straightforward to use, flexible, and high-quality when it comes to performing challenging data analysis or creating publication superior graphs."

Keith J. Stevenson, Professor of Chemistry, The University of Texas at Austin

Publish, Present, Report

Create publication-quality reports inside Origin, or embed graphs in Word® and PowerPoint®.

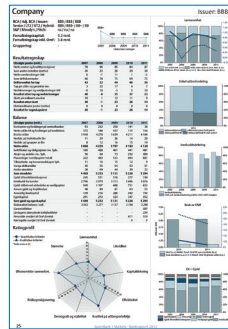

Custom Report Sheets created by combining graphs and analysis results

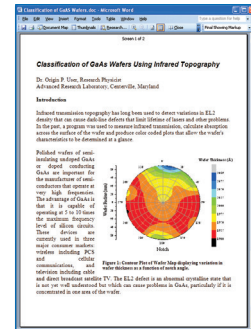
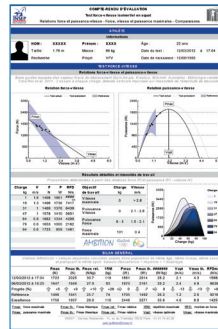

Copy and OLE-paste graphs in Word

Recalculate analysis results, and update graphs and reports by simply importing new data.

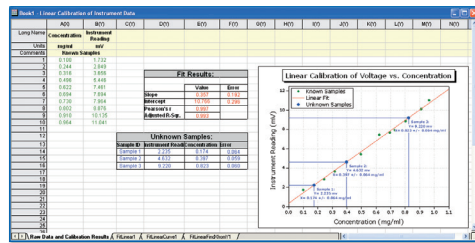

Analysis Template™ combining data, results, and floating graph

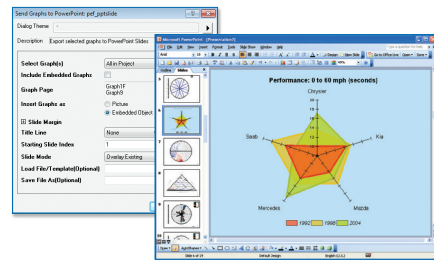

Send graphs to PowerPoint or view as slide show within Origin

Reduce, Summarize, Analyze

Reduce, summarize, and analyze data. Use Gadgets to graphically analyze data within a region of interest.

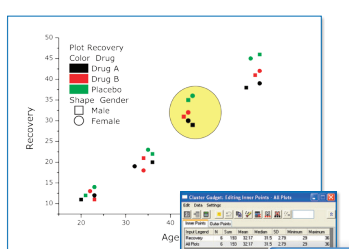

Use Gadgets for interactive analysis on data in graphs

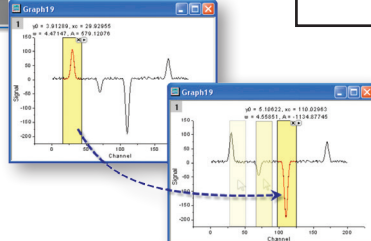

Origin provides advanced data analysis tools such as the Nonlinear Curve Fitter

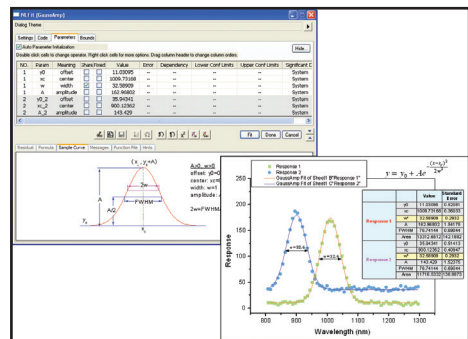

What's New in Origin 2017*

Origin Central

Origin has a new "startup" dialog to assist you with your day-to-day graphing and analysis tasks.

- Open scores of linked sample graphs and analyses without closing your current project.
- Open recent project, workbook or graph files.
- Create custom blank workbook or matrix windows, on-the-fly.
- Browse popular or recently-updated Apps.
- View written or video tutorials on Origin.

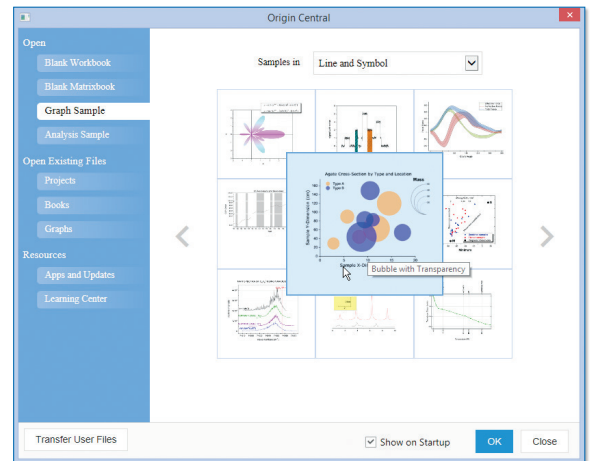

New Graphs and Graph Improvements

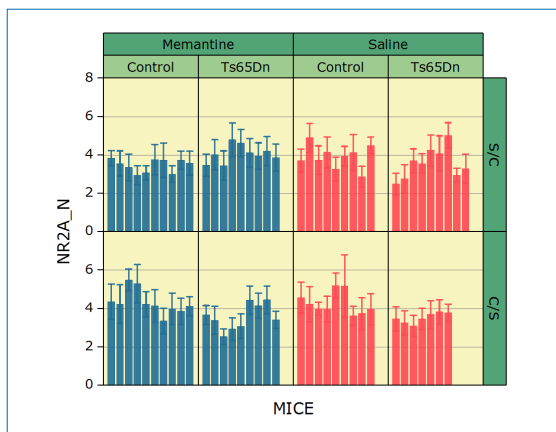

Trellis Plots

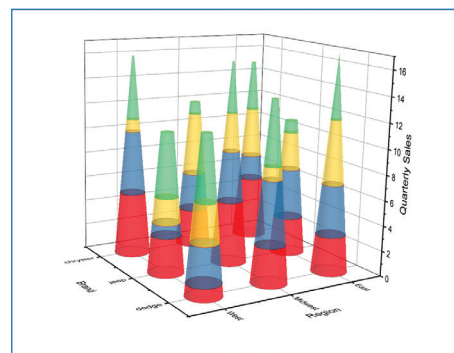

3D XYZ & XYZ Stacked Bar Plots
plus New Bar Shapes

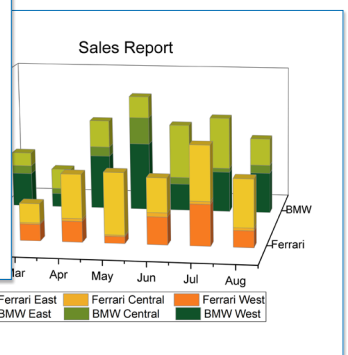

More Graph Improvements

- Box Plots: Connect means, data points or other percentiles. Statistical bars with data overlay.
- Histograms: Label with bin counts, %age or both.
- Grouped Plots: Unbalanced subgroups can display grid line separators, set gaps by dataset.
- Support for all 2D objects in 3D graphs: Table, image, drawn objects, bubble scale, OLE object.
- Axis improvements: Multiple reference lines and shading between in 2D graphs; more rescale options, tick labels combine column labels, leader lines for special ticks, wrap tick labels for 3D plots.
- Dropline direction control for 2D, 3D graphs.
- New system colors give your graphs a fresh look.

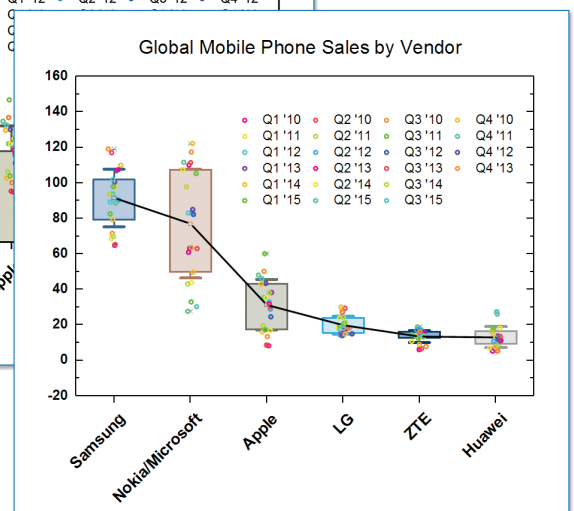
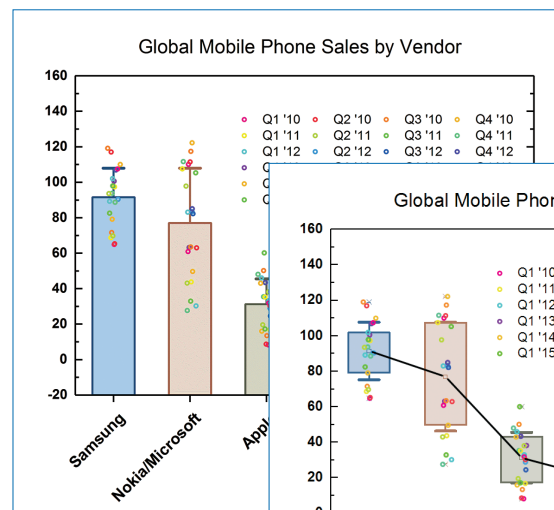

Simpler Spreadsheet Cell Notation

- New column formula notation is similar to Excel or Google Sheets.
- Auto- column short naming as columns are added, deleted or moved.
- Simple references to columns in other books/sheets.
- Compatible with Origin's older column formula notation.

	A(X)	B(Y)	C(Y)	D(Y)	E(Y)
Long Name	Time	Delta Temperature (K)	Delta Temperature (C)	Magnetic Field (Oe)	Position (mm)
Units	(sec)		(C)		
Comments			B-273.15		
Sparklines					
1	0.01	40	-233.15	60.6	101.7
2	0.02	40.5	-232.65	61.3	100.9
3	0.03	40.2	-232.95	61.9	100.3
4	0.04	40.1	-233.05	62.5	100.8
5	0.05	40.2	-232.95	63.1	100.8
6	0.06	39.6	-233.55	63.7	101.7
7	0.07	39.7	-233.45	64.3	100.8
8	0.08	39.8	-233.25	64.8	102

Annotation Tool Improvements

- New Annotation dialog with more controls.
- ALT + drag a dynamic label object from point to point.
- Annotation Tool now easier to find on the Tools toolbar.

New Plot Menu with Large Icons

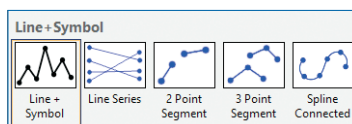

Geo Fill Patterns

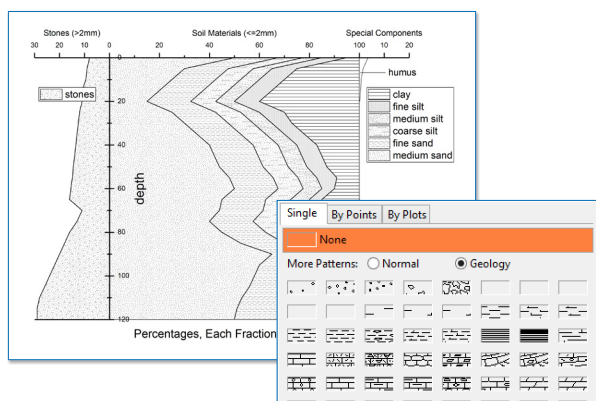

Programming: HTML Dialogs with JavaScript Support

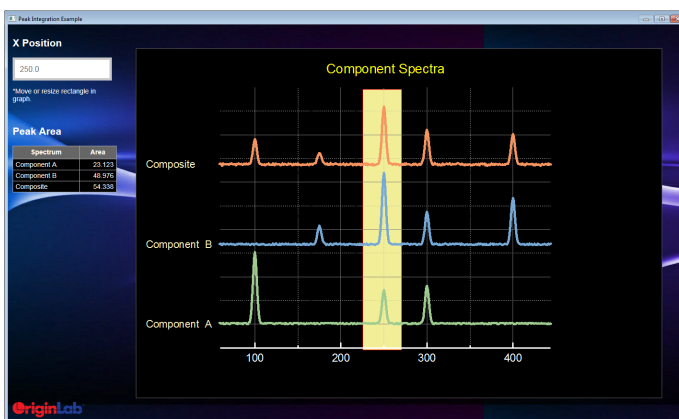

App Gallery Tabs

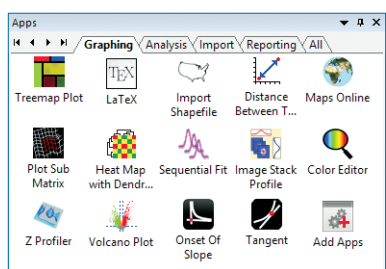

... plus ...

- General Linear Regression **PRO**
- Means Plot **PRO**
- 3D Stacked Histograms **PRO**
- Enzyme Kinetics **PRO**
- Piecewise Fit **PRO**
- Logistic Regression **PRO**
- Simple Time Series Analysis **PRO**
- Principal Component Analysis **PRO**
- ... and more

New Apps for 2017

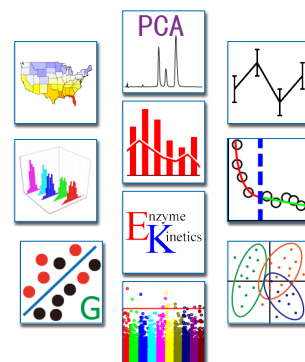

View more apps: www.OriginLab.com/Apps

*To view a complete list of reasons to upgrade go to: originlab.com/VersionComparison

2D Graphing

Origin provides many 2D graph templates including line, symbol, column, bar, pie, stock, statistical, contour and area. Specialized plot types include ternary, polar, vector, windrose, and waterfall.

Origin graphs can contain multiple XY axis pairs (layers) that can be arranged arbitrarily, including support for linking axes across layers. Multiple X and/or Y axes with offsets are supported. All graph elements can be easily and extensively customized, including color transparency and gradients.

Graph customization can be saved to a template or as a theme for repeated use.

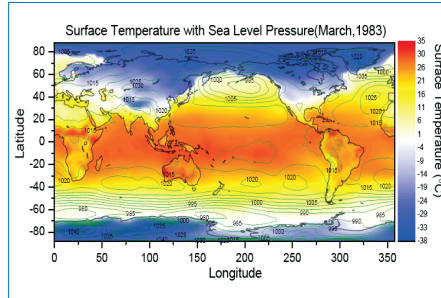

Overlay of Two Contour Plots

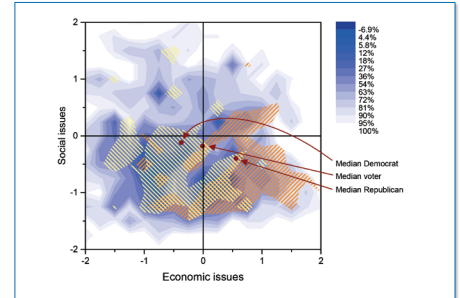

Pattern Fill Contour with Annotations

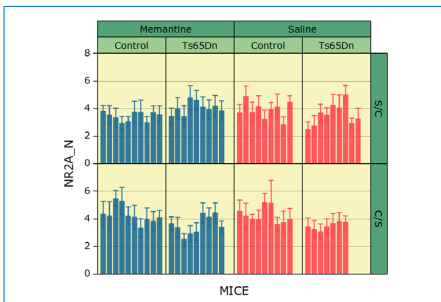

Trellis Plot

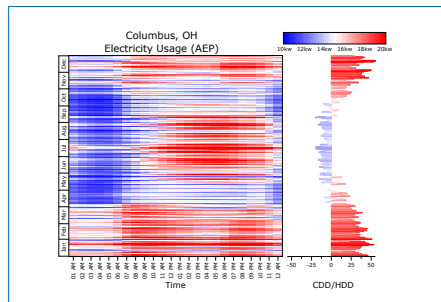

Heat Map

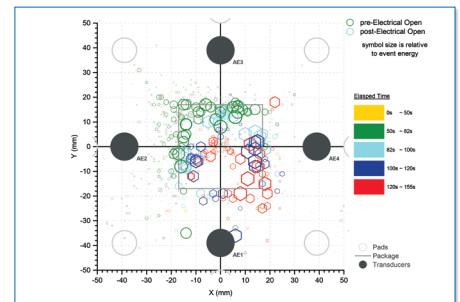

Scatter Plot with Color and Size Mapping

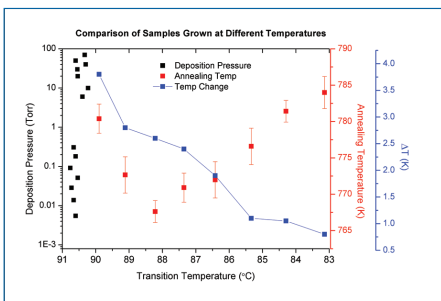

Overlapping Layers with Linked X Axis

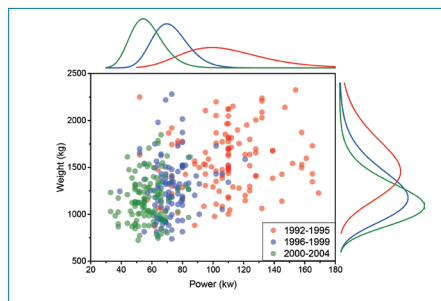

Marginal Distribution Curve Plot

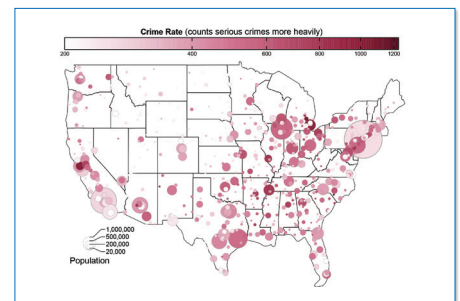

Bubble Plot on Map

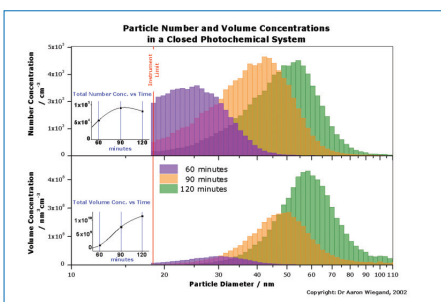
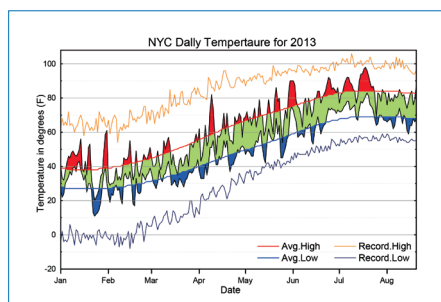
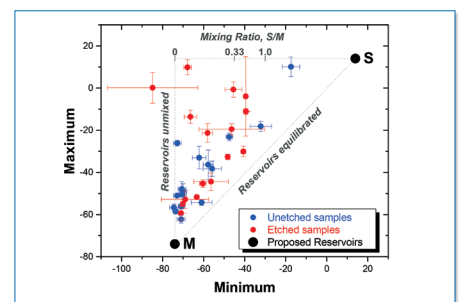

Chart with Inset Layers and Transparency



Line Plot with Above/Below Fill Color



Scatter with X and Y Error

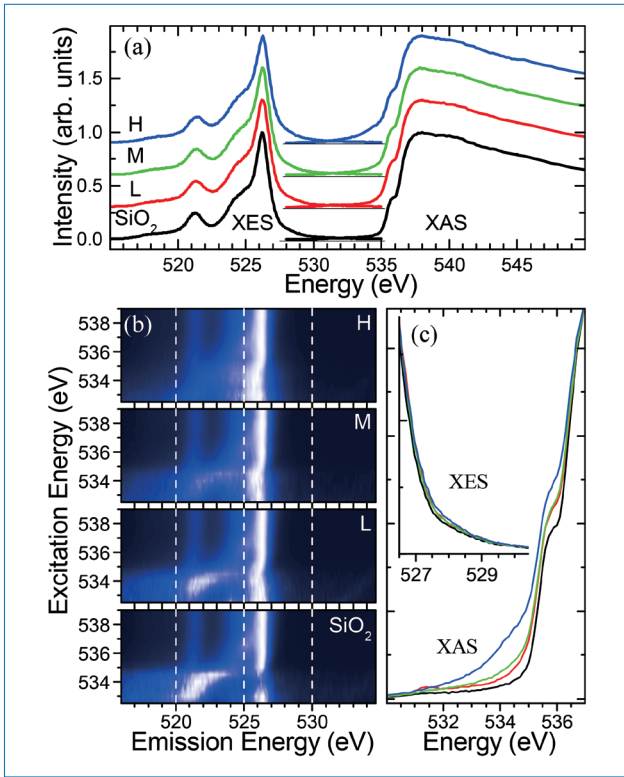

Arbitrary Arrangement of Graph Layers

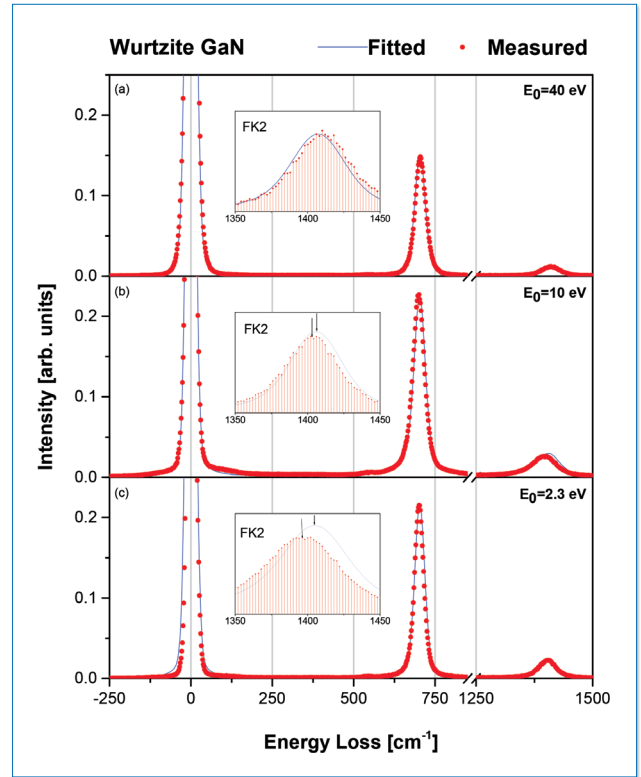

Stacked Layers with Linked X Axis

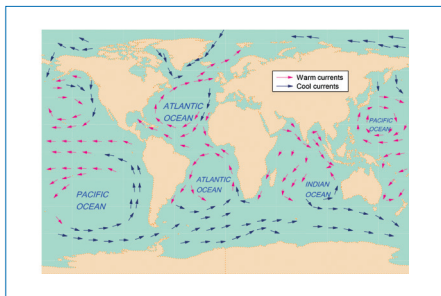

Fill Area with Vector Overlay

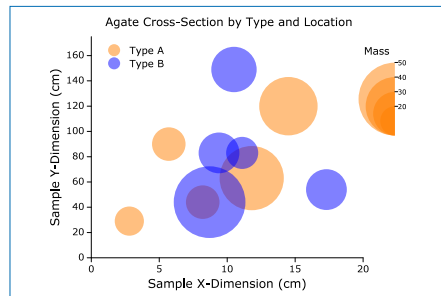

Bubble Plot with Indexed Colors

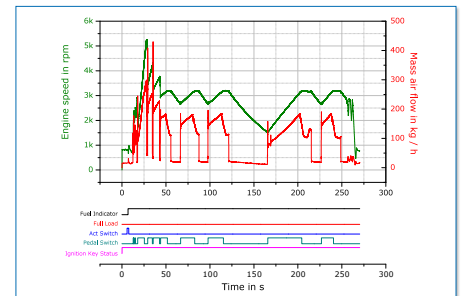

Bitspur Plot

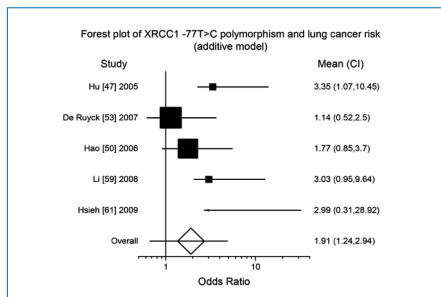

Forest Plot

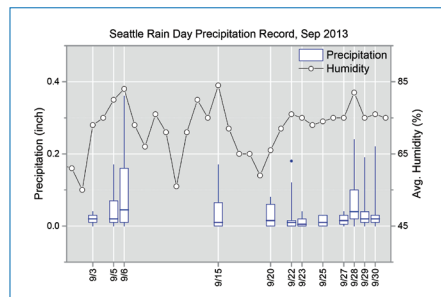

Box Chart with Variable Position

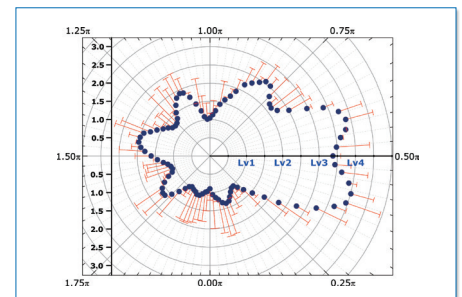

Polar Plot with Cropped Axis

2D Graphing (continued...)

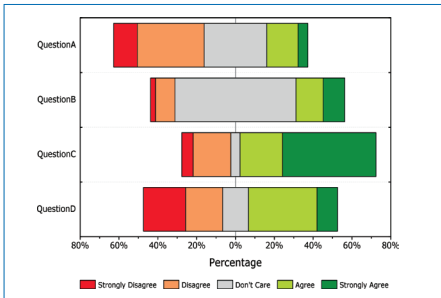

Likert Scale

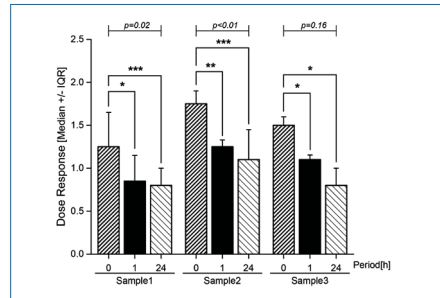

Grouped Column Plot with Asterisk and Bracket

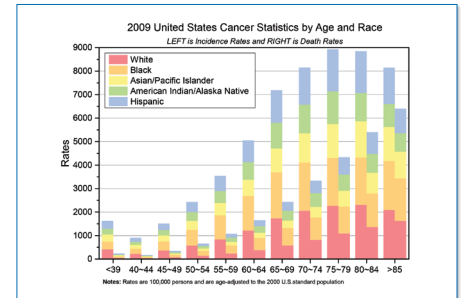

Grouped Stacked Column

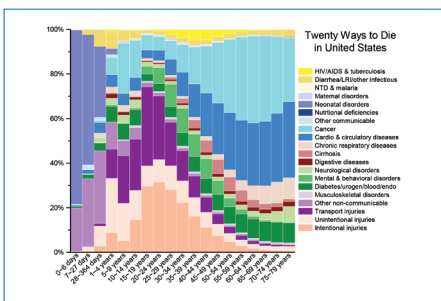

100% Stacked Column

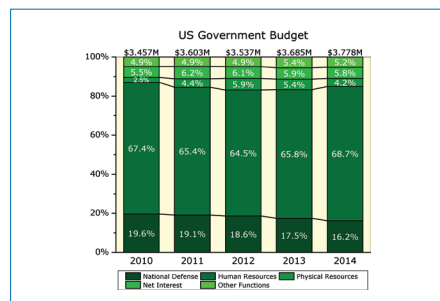

100% Stacked Column Plot with Line Connect

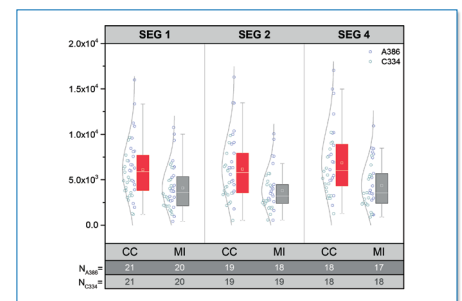

Grouped Box Chart with Color-Indexed Data Points

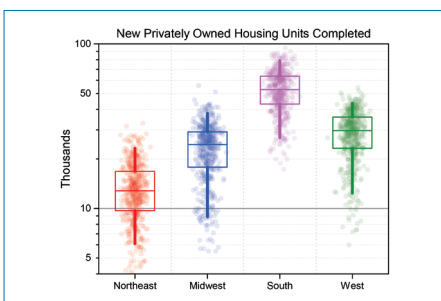

Box Chart with Data Overlay

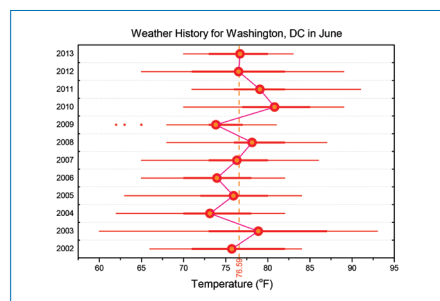

Horizontal Box Chart with Means connected

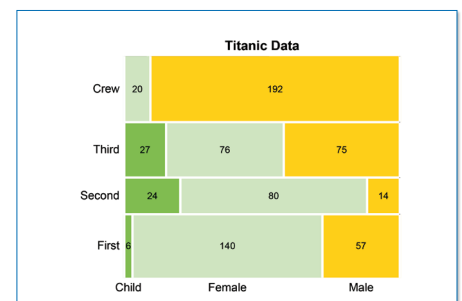

Mosaic Plot

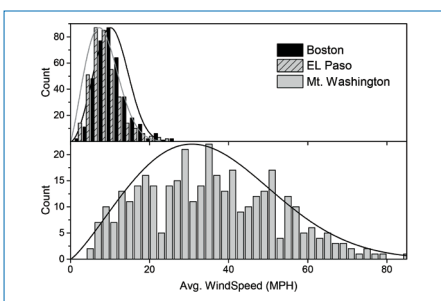

Stacked Histogram with Weibull Curve Overlay

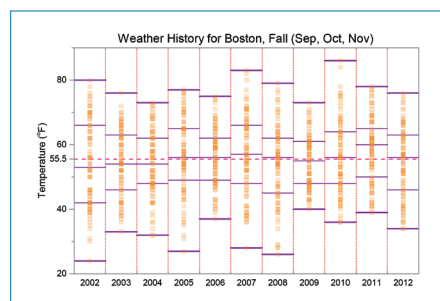

I-Shaped Box with Data Points

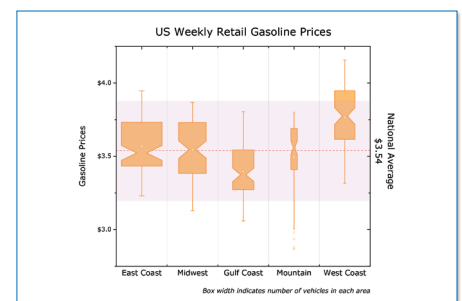

Box Chart with Variable Width

View more graphs at: originlab.com/GraphGallery

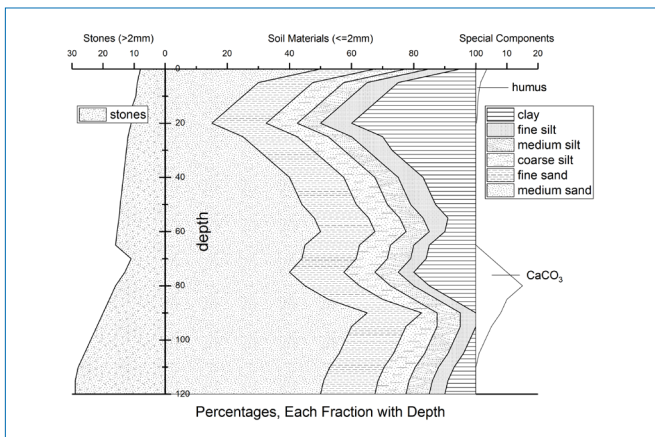

Stacked Area Plot with Geo Patterns

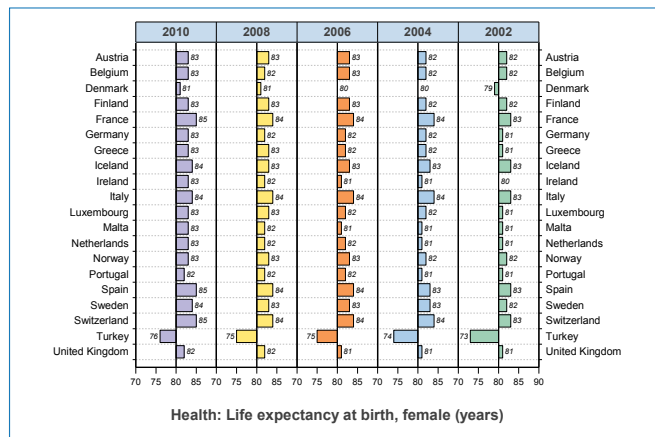

Trellis Plot

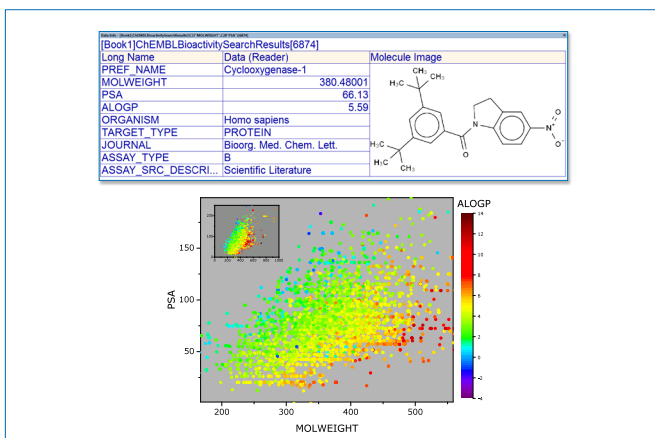

Scatter Plot and Data Info Dialog

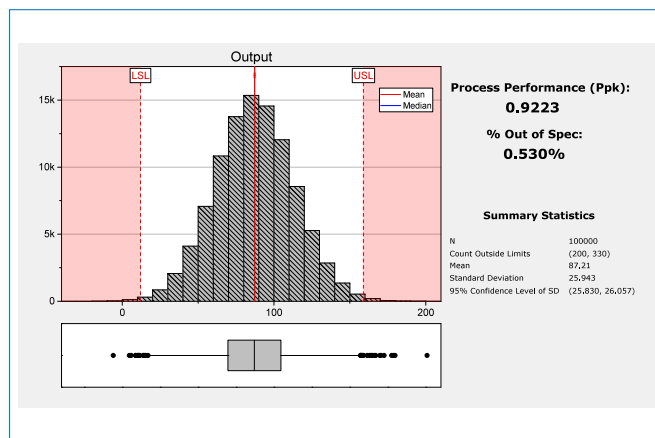

Monte Carlo Simulation

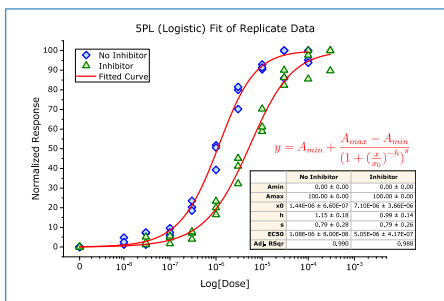

Dose Response Analysis

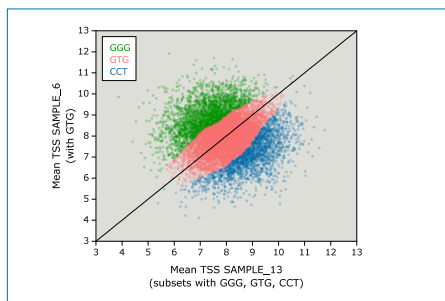

Scatter with Color Indexing

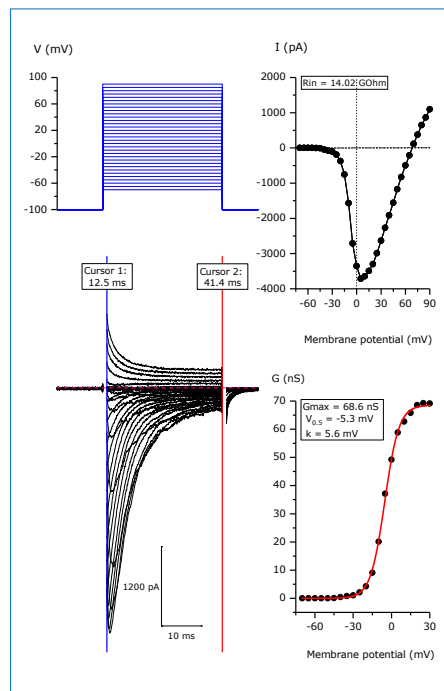

Multipanel Plot of pCLAMP Data

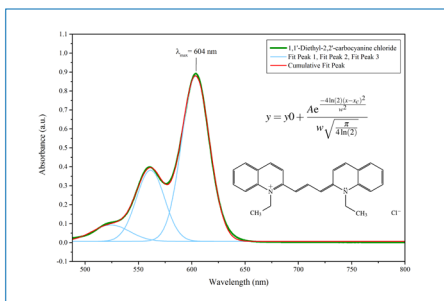

Annotation with Equation and Molecular Image

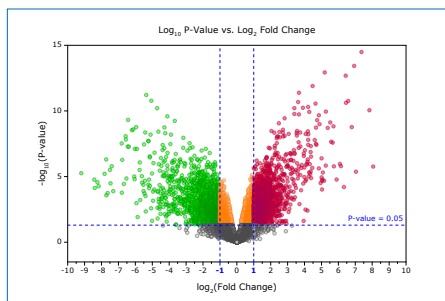

Volcano Plot

View more graphs at: originlab.com/GraphGallery

2D Graphing

(continued...)

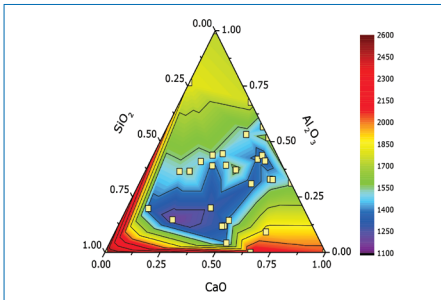

Ternary Contour

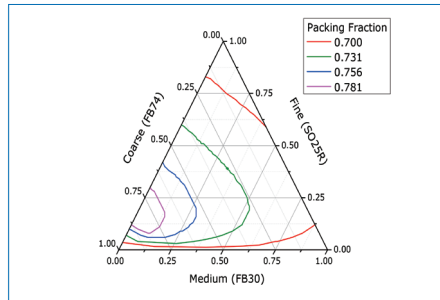

Ternary Plot

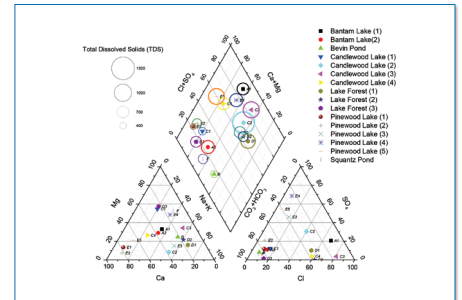

Piper Diagram

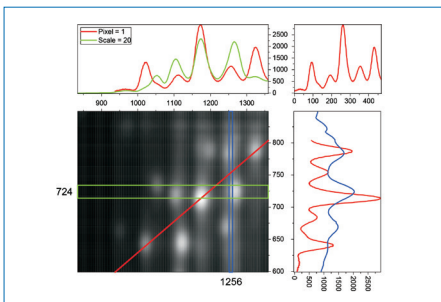
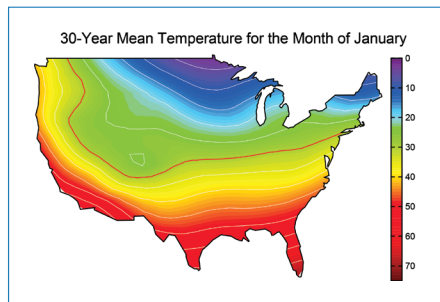
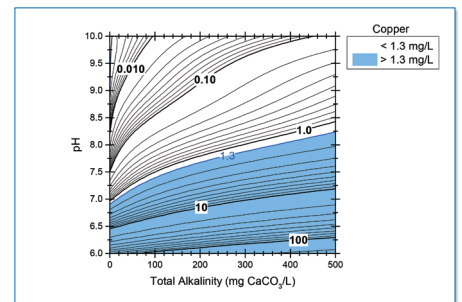

Image Profile



Contour Plot with Custom Boundary



B&W Contour Plot with Fill

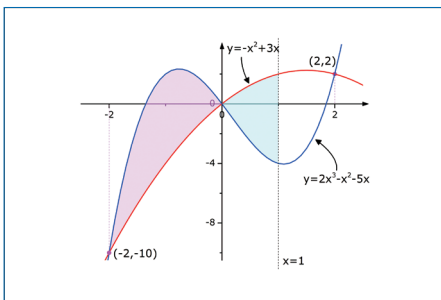

Function Plot with Fill Area

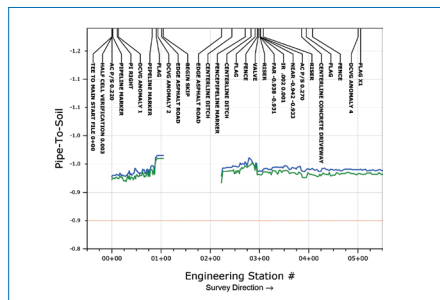

Smart Labeling with Leader Lines

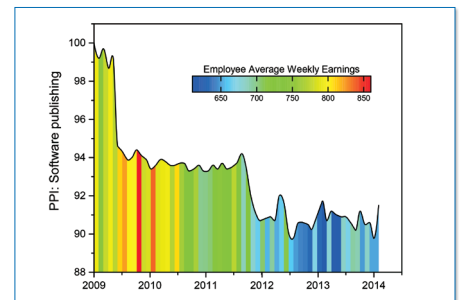

Fill Area Color Mapped to Another Dataset

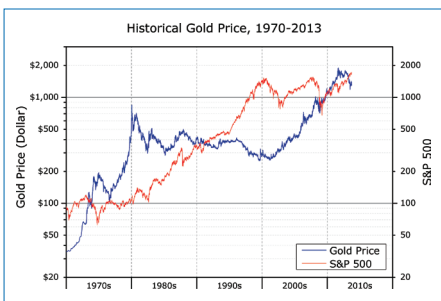

Grouped Line Plot with Log Scale

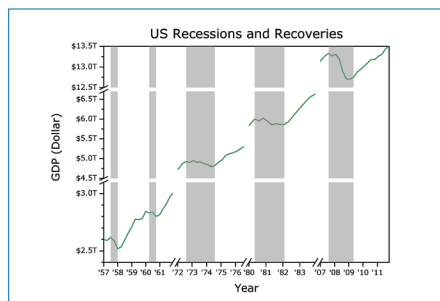

Multiple Axis Breaks and Reference Lines

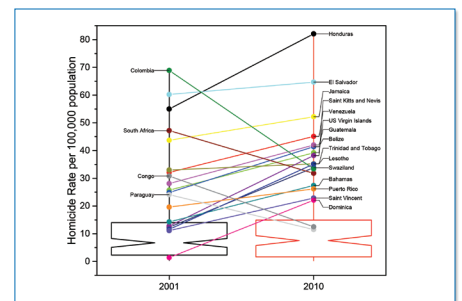

Two-Point Segment Line Plot on a Box Chart Background

View more graphs at: originlab.com/GraphGallery

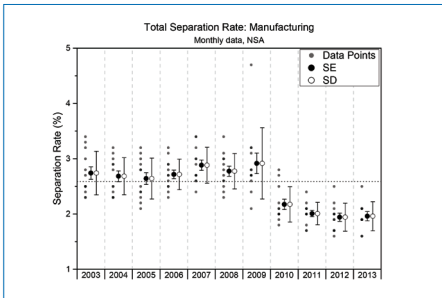

Scatter with Offset

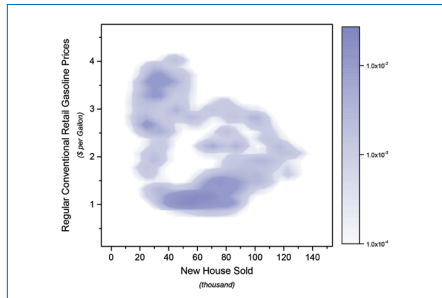

2D Kernel Density Plot

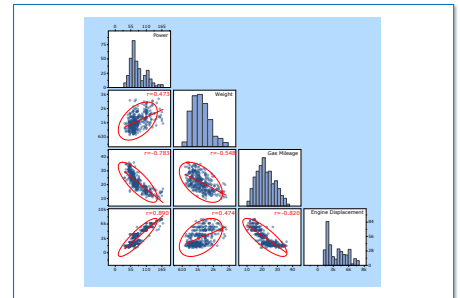

Scatter Matrix with Histograms

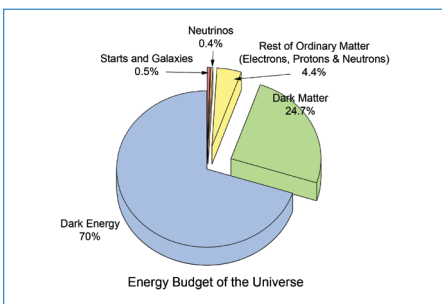

3D Pie Chart

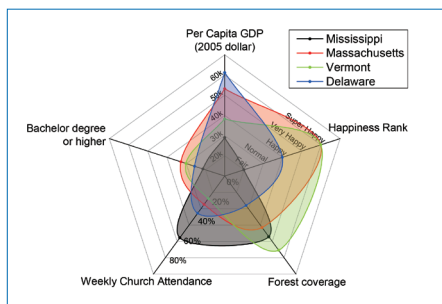

Radar Chart

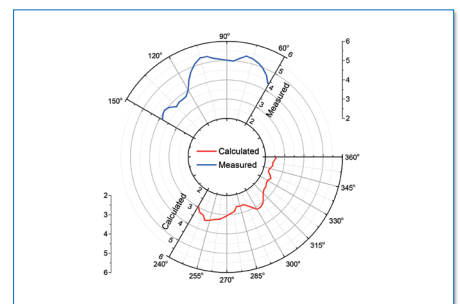

Multi-Layer Polar Plot

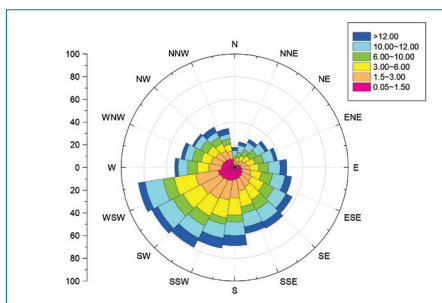

Windrose Plot

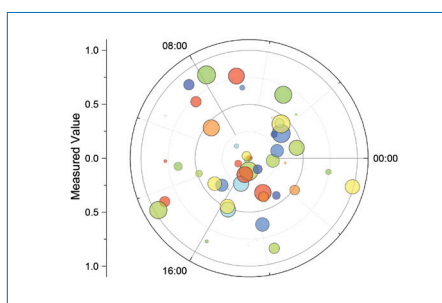

Polar Scatter



Polar Line Plot with Colormap

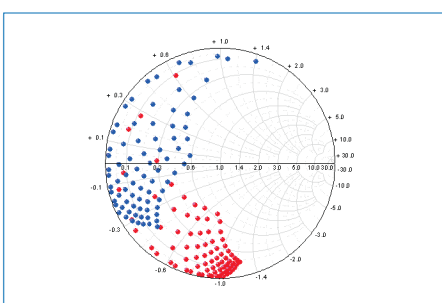

Smith Chart

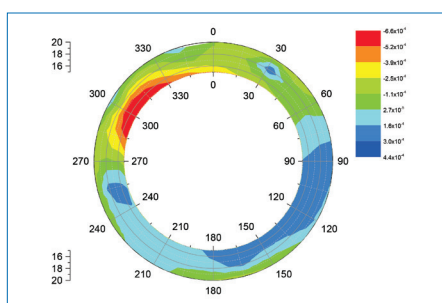

Donut Contour

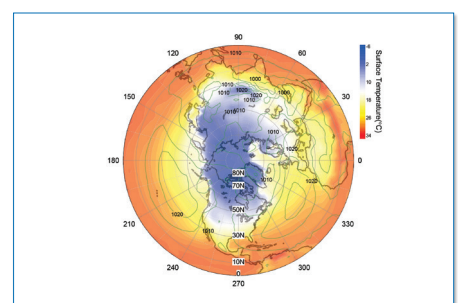

Polar Contour

View more graphs at: originlab.com/GraphGallery

3D Graphing

Origin provides high-performance 3D graphs and parametric function plots, created using OpenGL. Many built-in templates such as wireframe, colormap surface with contour projection, scatter, bars, ribbons, and walls are provided. Multiple datasets can be plotted in the same layer, with ability to stack and flatten each dataset individually. Error bars are supported for many of the plot types. Changes can be saved as template or theme for repeat use.

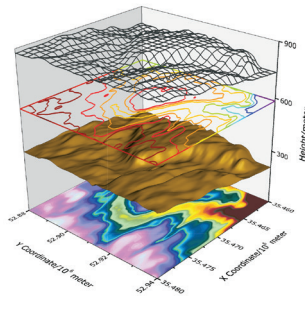

Stacked Plot with Contour, Surface, and Wireframe

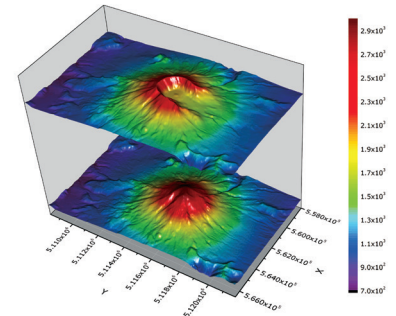

Stacked Surface Plot

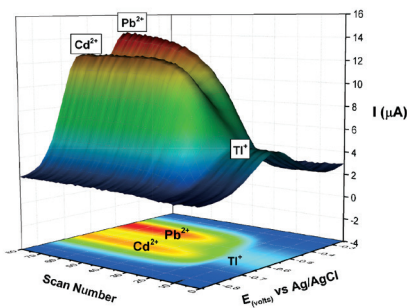

Surface Plot with Contour Projection

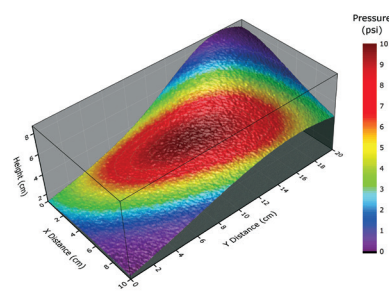

Surface Plot with Colormap from Another Dataset

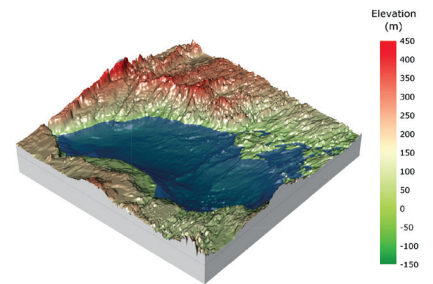

Surface Plot with Constant Plane

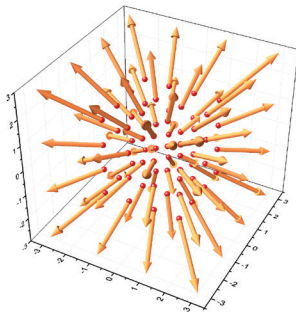

3D Vector Plot

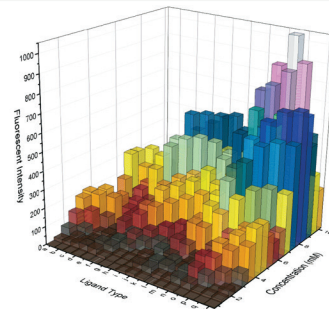

Bar Plot with Transparency

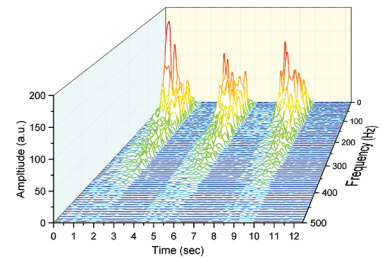

Waterfall with Y-Color Mapping

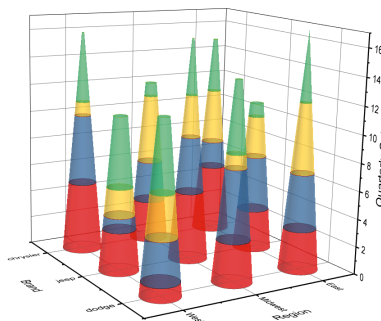

3D Stacked Bars with Transparency

Monthly US House Price Index vs. Number of Houses for Sale
Not Seasonally Adjusted, January 1991 = 100

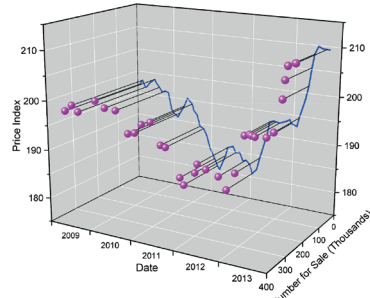

Scatter with Projection and Drop Line

US Metropolitan Population Distribution

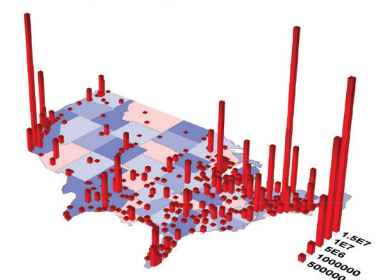

Contour and Bar Plot

View more 3D graphs at: originlab.com/GraphGallery

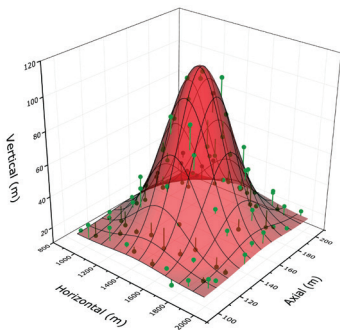

Surface Plot with Scatter and Drop Lines to Surface

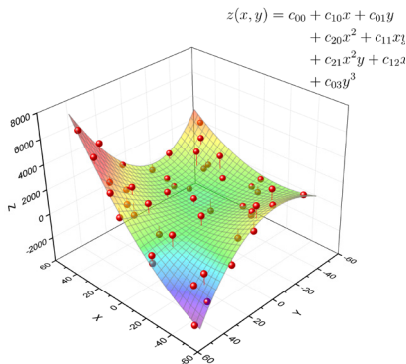

Surface Fit with Polynomial Equation

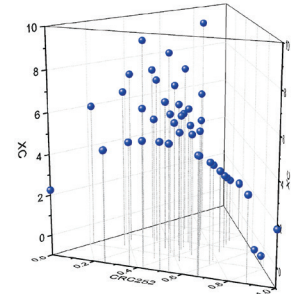

Ternary Scatter with Drop Line

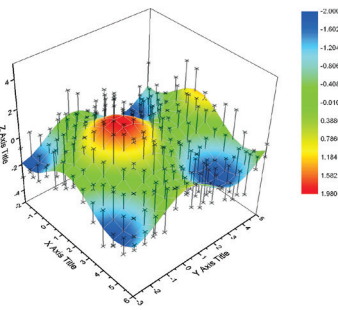

Surface with Error Bars

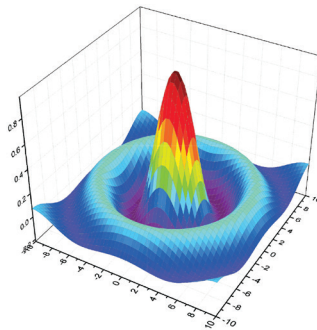

Surface with Piece by Piece Fill Color

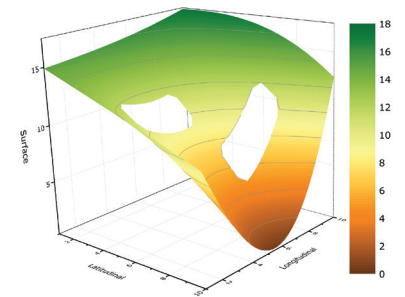

Surface Plot with Missing Values

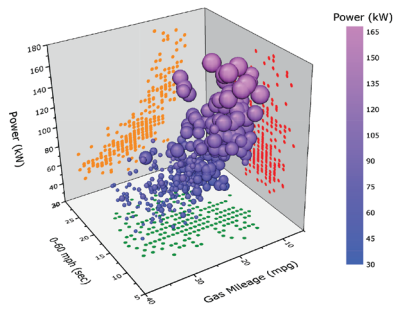

Symbol Size proportional to Engine Displacement

Scatter Plot with Size and Color Mapping

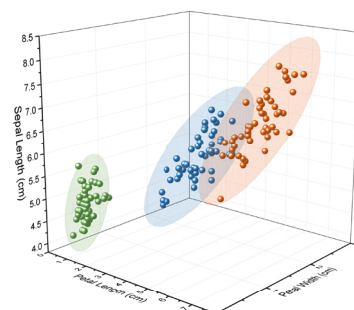

3D Scatter with 95% Confidence Ellipsoids

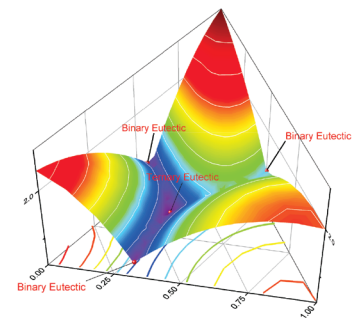

Ternary Surface

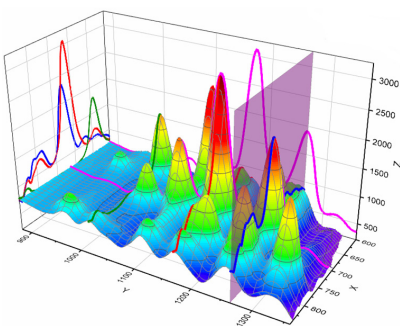

3D Wall Profiles

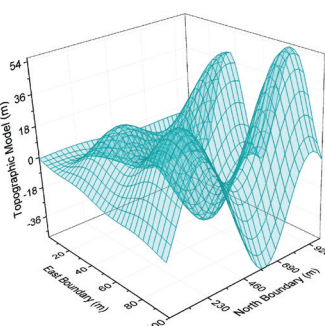

Wireframe Plot

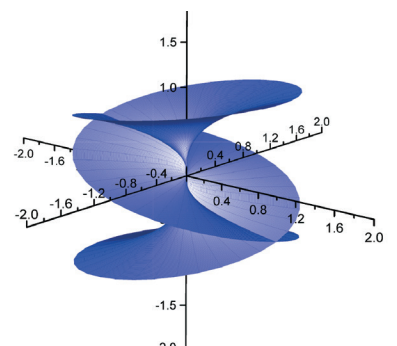

3D Function Plot with Custom Axis Position

View more 3D Function Plots at: originlab.com/3DFunctions

Database Access

Origin provides easy-to-use tools for database access. Connection and query information can be saved for future use in the workbook or project, allowing for greater ease and efficiency in working with databases.

Origin supports accessing and importing from many databases including:

- Microsoft Excel
- Microsoft Access
- Microsoft SQL Server®
- Oracle®
- MySQL®

SQL Editor

The SQL Editor tool in Origin is intended for users who prefer to work directly within the SQL environment. Quickly connect to a database by editing the connection string and SQL code in the syntax-highlighted editor. The editor is fully integrated with LabTalk, allowing the use of LabTalk commands and variables in an SQL query.

With the SQL Editor, you can:

- Fine tune how your data is brought into Origin
- Use aliases to make the SQL script more intuitive, easier to read, and faster to create
- Perform left or right joins when inter-joining tables
- Create union sub-queries

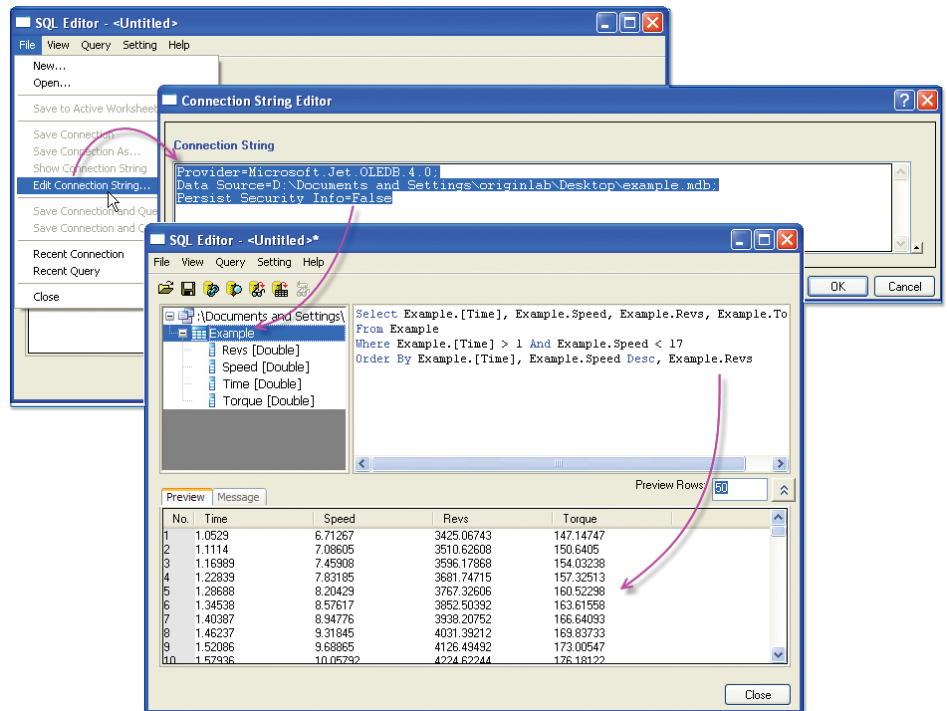

In SQL Editor, enter connection string and preview query results

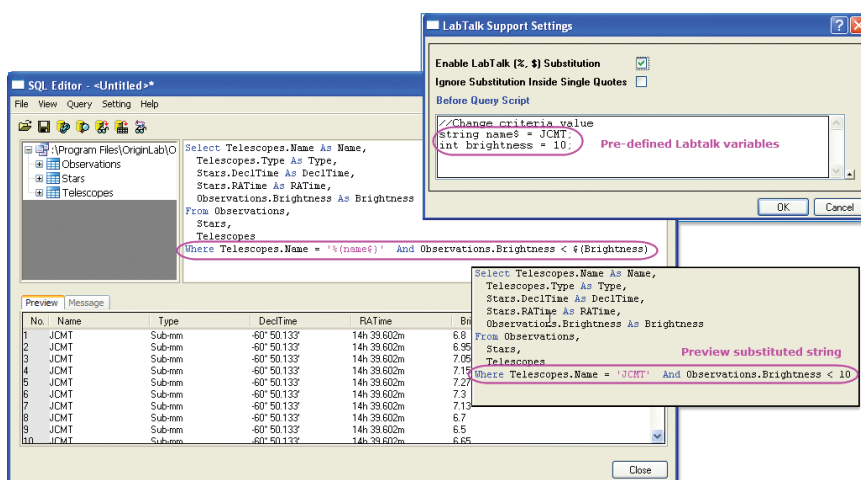

Use LabTalk substitution and pre-defined LabTalk variables in SQL query code

Query Builder

The Query Builder tool in Origin is a graphical interface that allows users to visually construct SQL queries, save named queries, and more.

This tool can detect relationships between tables and automatically create appropriate joins. Use Query Builder to define grouping, sorting, unions, sub-queries, and more, for creating complex SQL queries.

Connection and query information can be saved for future use.

With the Query Builder, you can:

- Manually type SQL code or create graphically
- View query tree and available database objects (tables)
- Drag and drop the desired tables from the object viewer to create your query
- Preview your query results before importing
- Save your named query with the worksheet and it then automatically reflects database change
- Re-run your query at any time to see the most current version of your data
- Copy queries from one worksheet to another
- View your query information in the Workbook Organizer
- Use your saved query as part of an Analysis Template™

Note: This tool is currently available only in the 32-bit version of Origin.

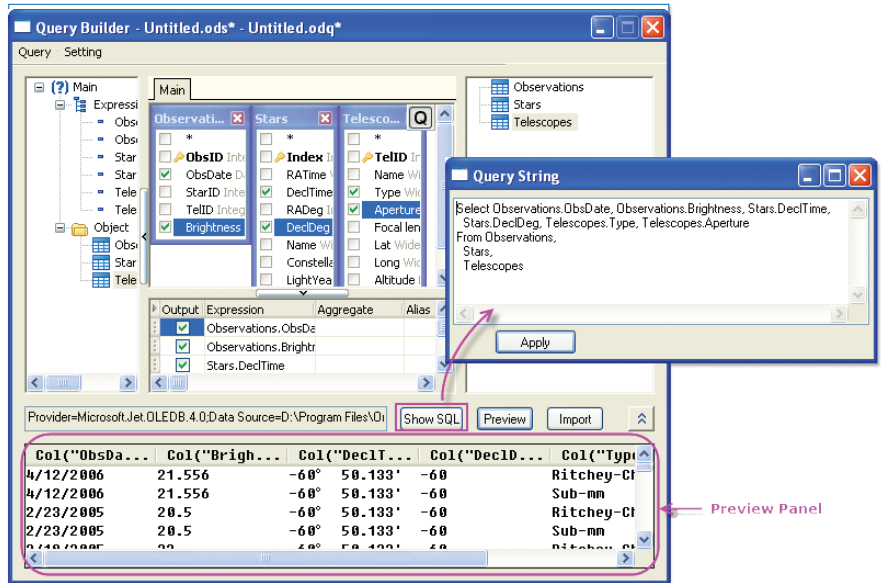

The Query Builder dialog

Post Import Data Processing

As a powerful data analysis and graphing software, Origin provides a wide array of tools to perform post processing of data imported from a database:

- Generate publication-quality 2D or 3D graphs with large datasets, and easily zoom and pan within the graph to visualize your data
- Use data reduction tools such as data filter or pivot table to reduce or summarize large data
- Perform analysis operations on your data such as curve fitting or statistical analysis
- Automatically update graphs and analysis results when you re-import data, or change data or analysis parameters

Database Server

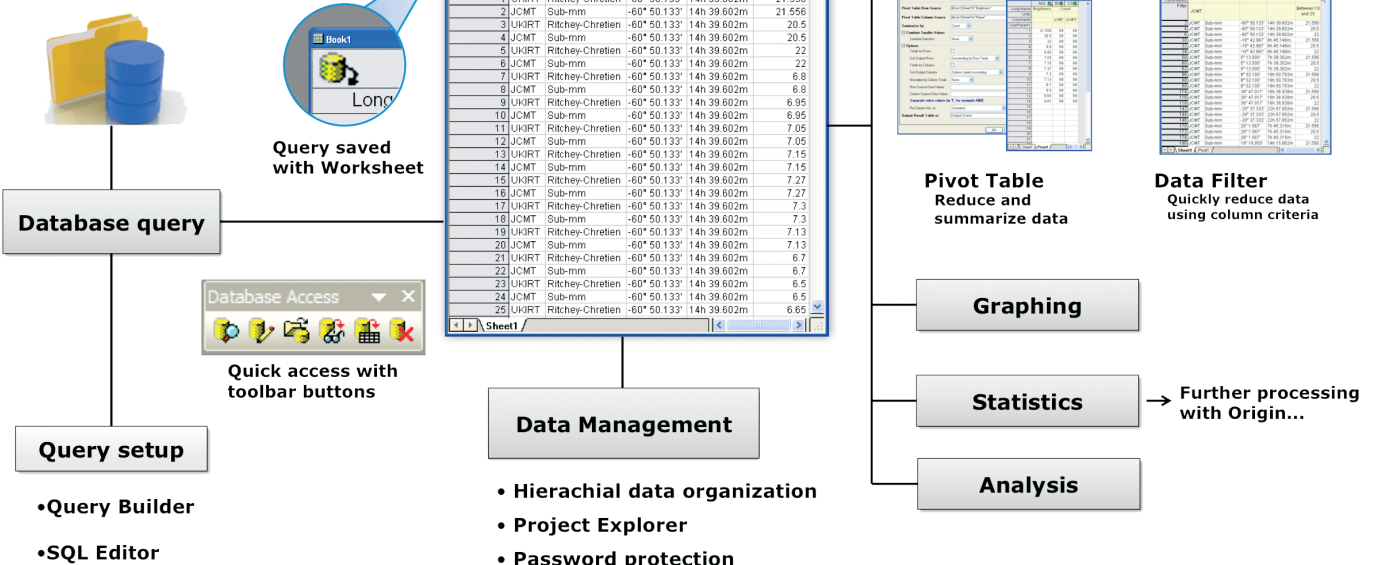

Data Processing

Organizing Your Data

Origin provides an easy, flexible, and hierarchical approach to organize your data:

- The Origin Project file (.OPJ) combines data, notes, graphs, and analysis results in one document with flexible hierarchy for folder structure
- The Project Explorer window allows easy navigation within the project
- Workbooks and Matrices support multiple sheets, columns/objects, and an organizer panel for additional metadata

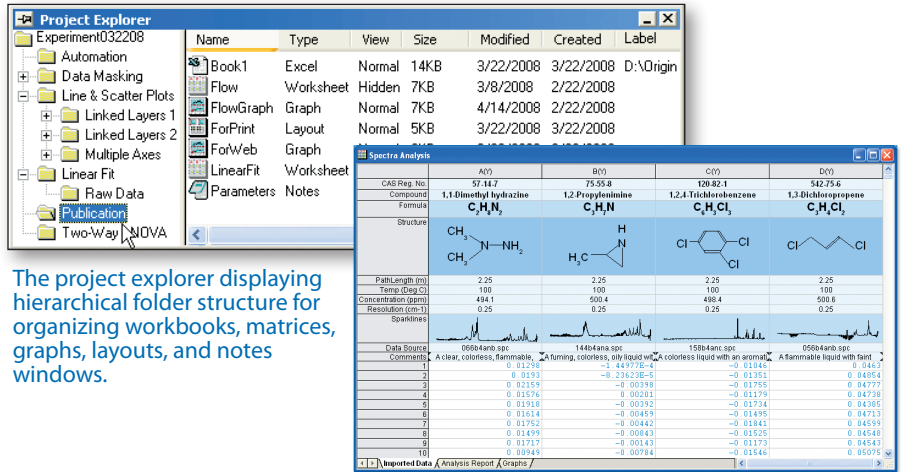

The project explorer displaying hierarchical folder structure for organizing workbooks, matrices, graphs, layouts, and notes windows.

Workbook with multiple sheets, data columns, metadata label rows, and sparklines.

Data Exploration

Origin provides easy to use tools to examine and interact with your graphical data:

Zoom and Pan

- Magnify a region of the graph
- Easily zoom and pan to desired X/Y scale
- Plot zoomed region as a separate graph

Examine Data Points and Related Data

- Use Data Reader and Screen Reader tools to examine your data
- Use Data Info tools to read or label data points, displaying the related information from other columns in the data worksheet
- Use masking tools to allow you to exclude data points from analysis
- Use the Vertical Cursor Gadget for exploring data in stacked graphs

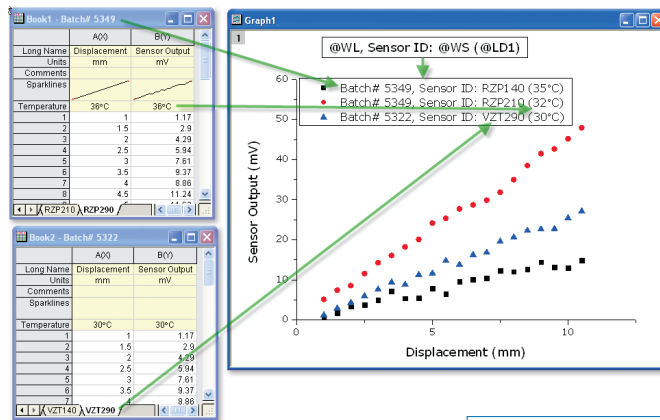

Use metadata from multiple locations in your workbook to annotate your graphs

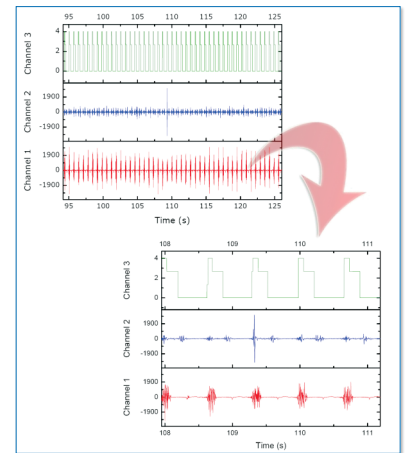

Zoom and pan to the desired X/Y scale

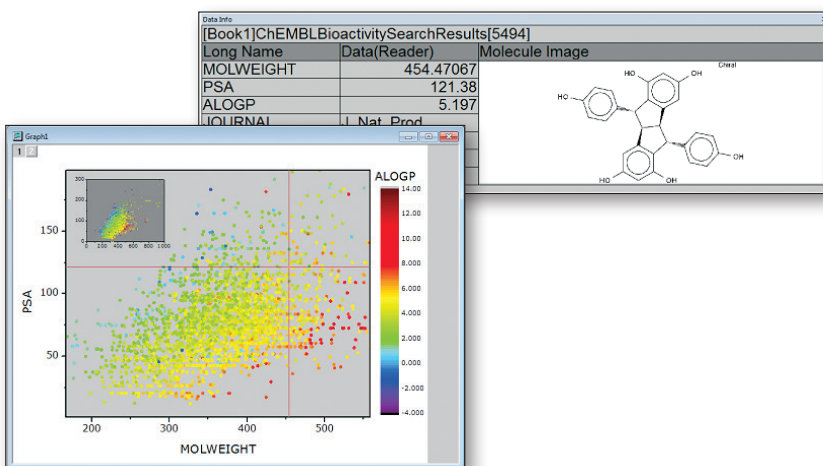

The Data Info tool lets you explore data from your graph, including display of related information from other columns

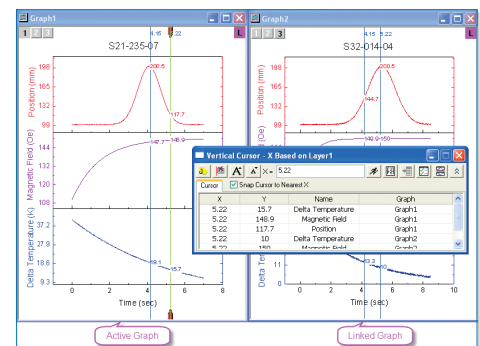

Use vertical cursor for multiple graph windows simultaneously

Data Manipulation

Reorganize, reduce, extract, and transform your data in flexible ways using Origin's powerful data manipulation tools.

Reorganization

- Sort data at column or worksheet level
- Stack and Unstack columns to transform data
- Split or Append Worksheets
- Transpose Worksheet including Metadata Rows

Transformation

- Set Column Values using Built-in or User-Defined Functions or script
- Access and use Metadata, and Data from other Books and Sheets
- Shrink or Expand data in a matrix

Extraction, Reduction, and Interpolation

- Filter your data using conditions on one or more worksheet columns. All associated graphs and analysis results will automatically update.
- Use Pivot Table to reduce and summarize your data
- Reduce data using multiple methods such as Evenly Spaced X, Duplicate X, Reduce by Rows, or Reduce by Group
- Interpolate or Extrapolate data columns
- Fill data automatically in worksheet cells

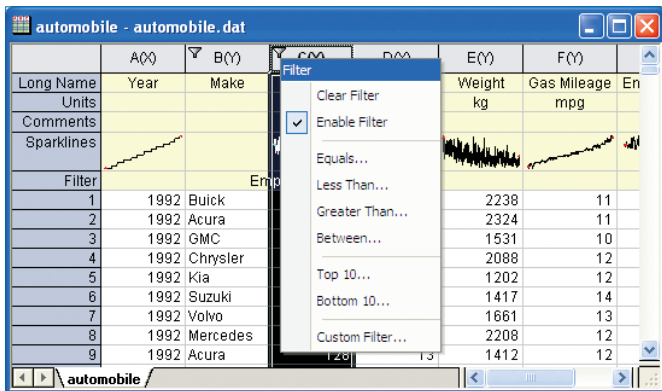

Data Filter capability can be used to hide rows based on filter conditions on columns. Hidden rows are excluded from graphing and analysis

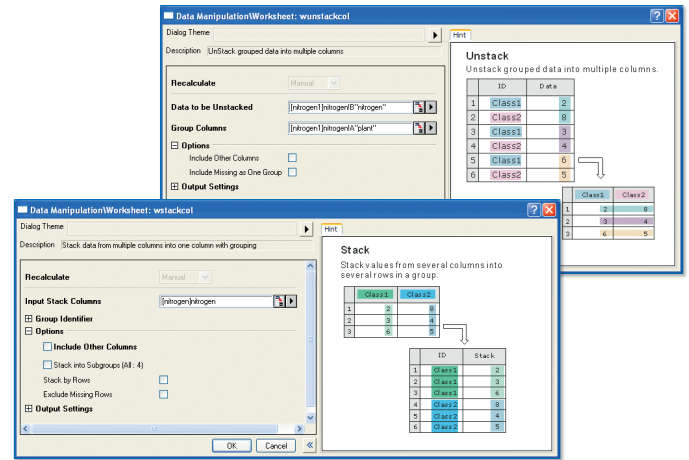

The Stack/Unstack tools enable the user to stack multiple data columns into a single column and unstack grouped data into multiple columns.

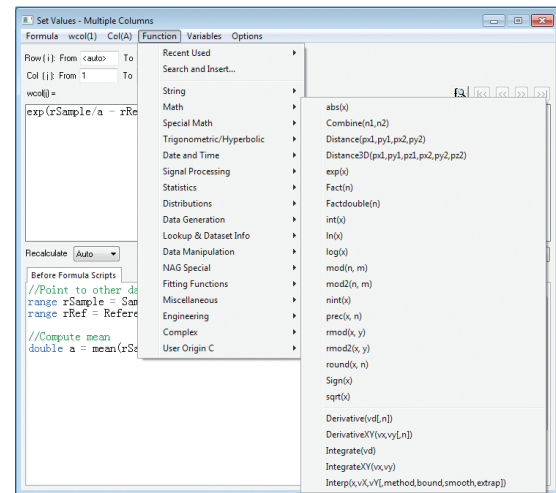

The Set Column Values dialog offers a large collection of built-in functions, the ability to access other columns, and perform advanced data manipulation, using LabTalk script

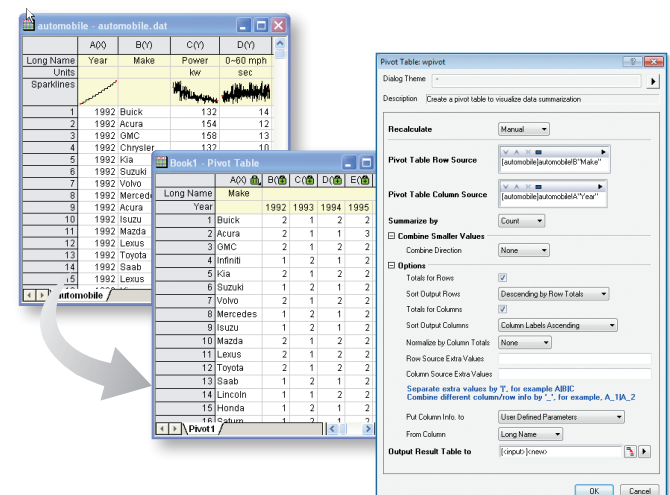

Gadgets

When your data is plotted in a graph, Origin gadgets provide a quick and easy way to perform exploratory analysis on the graph. Perform the analysis on a specific range of the data plot by appropriately positioning a region-of-interest (ROI) object to select the desired range. The ROI object provides a fly-out menu with various options that are tailored to each specific gadget. All gadgets have a fly-out menu with a Preferences option allowing you to customize desired settings.

With Origin gadgets you can:

- Select the desired data range for analysis directly from the graph
- Get immediate visual output of results
- View updated results on screen when the ROI is moved or resized
- Customize the output, including appending results to a worksheet for each ROI position
- Save settings as a Theme for repeat use
- Repeat analysis on all curves in graph layer/page

A selection of the gadgets available in Origin and OriginPro are described below. Please see other sections for additional gadgets.

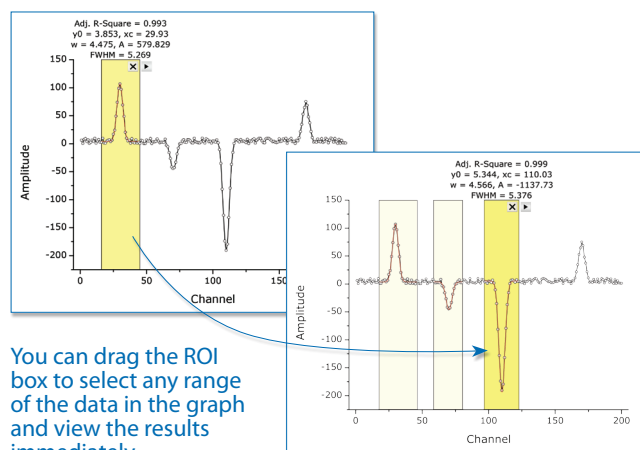

You can drag the ROI box to select any range of the data in the graph and view the results immediately

Digitizer Gadget

Extract data from images of graphs

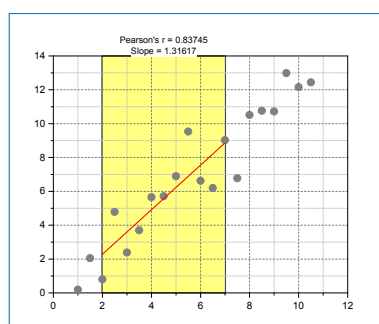
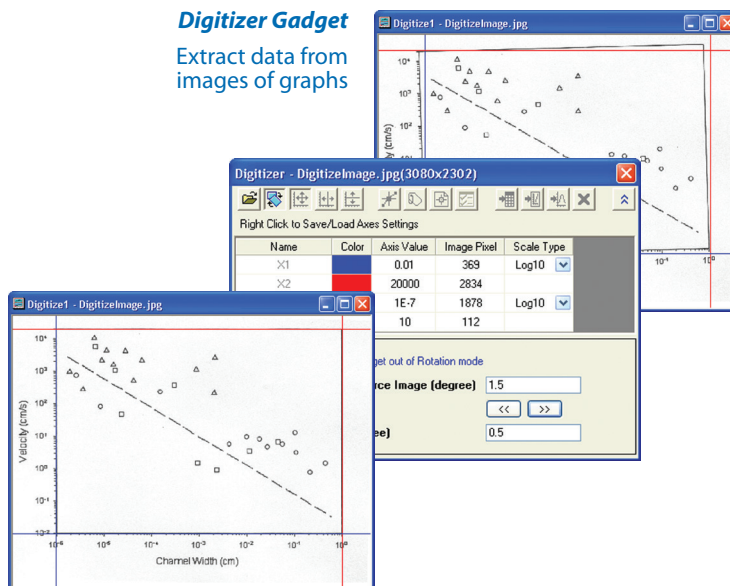

Quick Peaks Gadget

Interactively perform peak finding, baseline subtraction, and peak integration of data from a graph

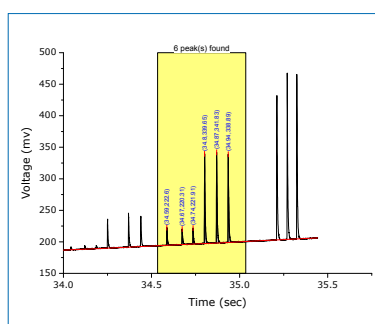

Quick Fit Gadget

Perform linear, polynomial, or nonlinear curve fitting on data plots in a graph

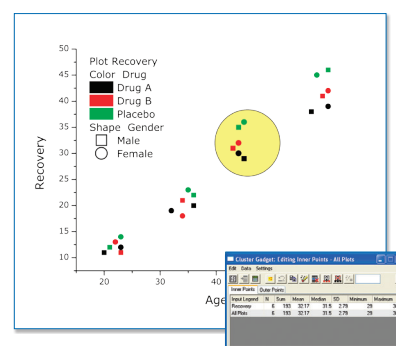

Cluster Gadget

Perform basic statistics and editing of data points within a region

“When working with many data points, graphing is often the quickest way to qualify data and identify trends. With the Origin statistics gadget, it’s also easy to pull quantitative information, such as mean and standard deviation, straight from a data plot. This lets me make better decisions about which data to select for more detailed analysis.”

Boaz Vilozny, Postdoctoral Researcher, University of California at Santa Cruz

Apps in Origin

Extend Origin's graphing and analysis capabilities by installing Apps.

Available Apps can be viewed from the Origin Central dialog or the Tools menu. Simply select the desired App, download, and then drag-and-drop onto Origin to install.

Apps are based on requests from Origin users. Have a suggestion for a new App? Contact us!

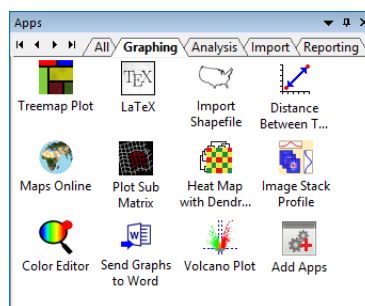

A multi-tabbed, dockable **Apps Gallery** window provides quick access to installed Apps.

LaTeX

Add equations and other annotations such as molecular structures to graphs and layout pages.

Maps Online

Fetch map images from WMS servers to places as background in Origin graph layers.

Tangent

Draw tangent line at selected point of a data plot.

3D Confidence

Add Confidence Ellipse to 3D Scatter Plots.

Z Profiler

Generate XY Contour data at specific Z values from 3D Surface Plots.

3D Wall Profile

Create XZ and YZ wall profiles from 3D surface plots

View more apps: www.OriginLab.com/Apps

"I am beyond pleased with the latest version of OriginPro compared to past versions that I have used. The apps provided additional features that are very helpful and useful."

Jacqueline Yim, Sr. Scientist, Advanced Development Group Aerospace, Defense & Marine, TE Connectivity

Curve Fitting

Origin provides various tools for linear, polynomial and nonlinear curve fitting. Fitting routines use state of the art algorithms and the report sheets including statistical quantities to determine goodness of fit. Create custom fitting reports and save your customization as an Analysis Template™ for repeat fitting including Batch Fitting of multiple datasets.

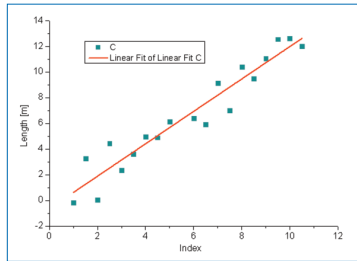

Linear

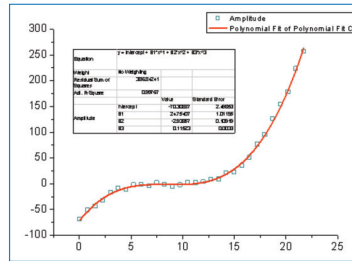

Polynomial

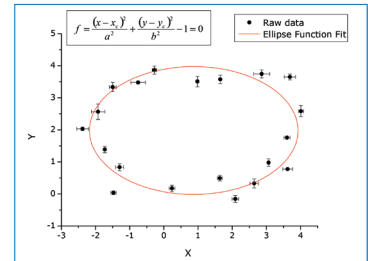

Implicit

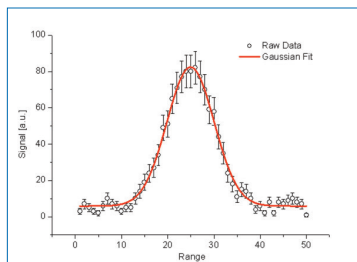

Weighted

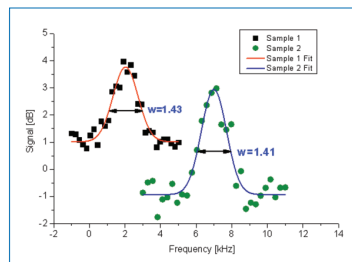

Global

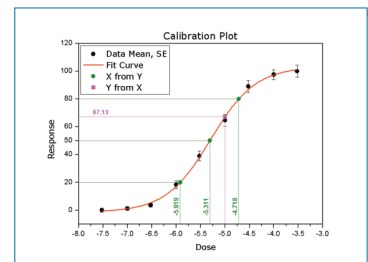

Concatenate/Replicate

Origin provides full control of the fitting process...

- Flexible data input
- Fit with various built-in functions, including both explicit and implicit
- A wizard for defining custom fitting functions
- Multi-dataset fitting modes: fit multiple datasets independently, in concatenate fit mode, or use a global fit with shared parameters
- Fit statistics and parameters output to the fit report
- Residuals analysis
- Interpolation on the fit curve to compute new X/Y values at desired locations
- Recalculation of your fitting results automatically when data or parameters are changed
- Analysis Templates™ to save your settings and desired results for repeat use or batch processing
- Iteration Algorithms: Levenberg-Marquardt and Orthogonal Distance Regression (Pro)

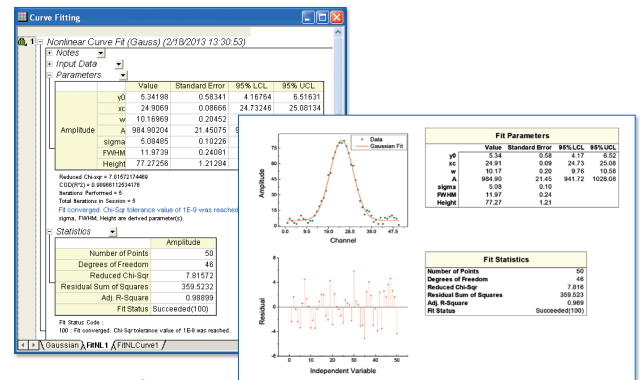

Use Origin's fit report sheets, or easily create custom reports by combining graphs and numerical results from the fitting process

Fit Comparison PRO

OriginPro provides the following tools for fit comparison:

- Compare two fitting models with dataset
 - F-test
 - Akaike's Information Criterion (AIC) test
- Compare one fitting model with two datasets
 - F-Test
- Fit dataset with multiple models and rank fit results using AIC /BIC test

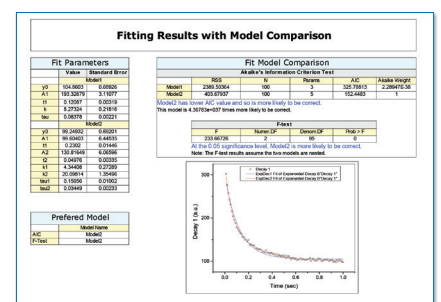
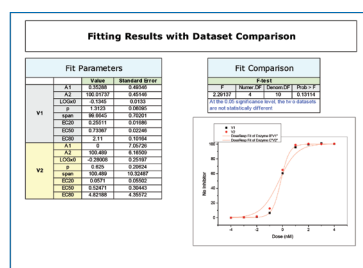

"Not only does Origin handle the most demanding curve fitting tasks with ease, it also has a built in C compiler that allows me to customize complex functions - a feature that has been crucial to my research. Origin is an indispensable tool to my grad students, whose PhD work hinges on being able to code our functions in C. To top it off, Originlab has a knowledgeable and responsive technical support staff, second to none. I wholeheartedly recommend Origin."

Mark Kuzyk, Ph.D., Regents Professor of Physics and Astronomy, Washington State University

Quick Fit Gadget

Origin provides a simple tool to quickly fit data plotted in a graph. Move or resize a region of interest (ROI) object to update results. Interactively perform fit operations on multiple ranges of the same dataset, or on multiple datasets in the graph.

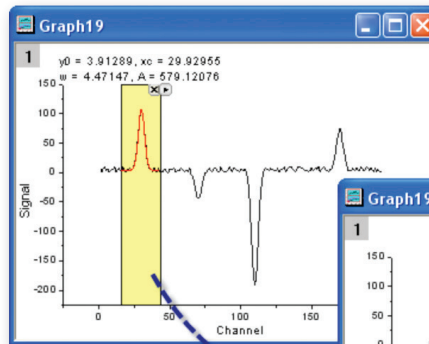

You can drag the ROI box to fit any sub range of the curve in the graph. Fit results displayed on the graph update immediately

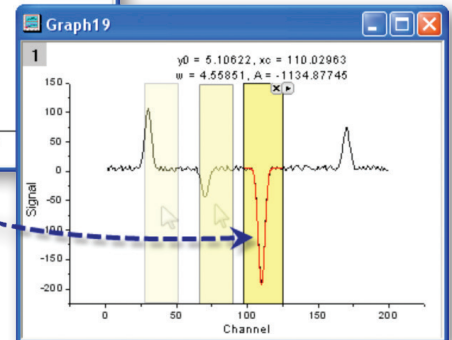

Fit parameters and other key values can be output directly to the graph or to a worksheet

Long Name	Function	Input	Range	Weighting	E(Y)	F(Y/Erz)	G(Y)	H(Y/Erz)	I(Y)	J(Y/Erz)
1	Gauss	Signal	[154:181]	No Weighting	4.56663	0.68765	170.00289	0.0641	4.64227	0.14407
2	Gauss	Signal	[141:168]	No Weighting	5.4106	0.58756	169.1392	1.31362	3.82151	1.20206
3	Gauss	Signal	[96:123]	No Weighting	5.40797	0.56778	110.02963	0.01825	4.56804	0.0409
4	Gauss	Signal	[61:88]	No Weighting	4.32127	0.60784	70.15248	0.07754	4.61447	0.17405
5	Gauss	Signal	[16:43]	No Weighting	3.91289	0.71431	29.92955	0.04407	4.47147	0.09838
6	Gauss	Signal	[157:184]	No Weighting	4.49203	0.65383	170.00288	0.06091	4.6491	0.13693

"The new Quick Fit Gadget is fantastic and I absolutely love that I can output results to a worksheet so that I can get a column of a particular parameter on which I can do statistical analysis."

Greg Scott, University of Illinois at Urbana-Champaign

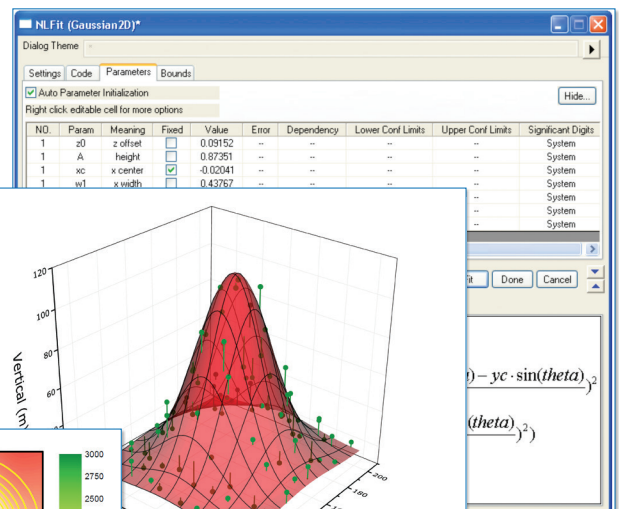

3D Surface Fitting PRO

Origin performs 3D surface fitting on XYZ worksheet data and matrix data using one of 19 built-in models or your own custom formula.

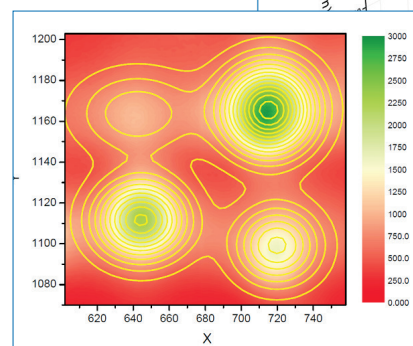

Contour plot displaying raw data and fit results from a 4-peak surface fit

Data points and fit surface are shown together. The fit surface has been made transparent to show more of the data. Drop lines from the data points to the surface have been added

Peak Analysis

Origin's Peak Analyzer is a powerful and versatile tool for peak and baseline detection and analysis.

- A wizard guides you through the fitting process
- Find and treat the baseline, find and select peaks, integrate peaks
- Generate a detailed report sheet with tables and relevant graphs
- Generate a worksheet with peak properties, including FWHM, centroid, area, peak index, and y-max

The additional features of peak fitting and baseline fitting described below are only available in OriginPro.

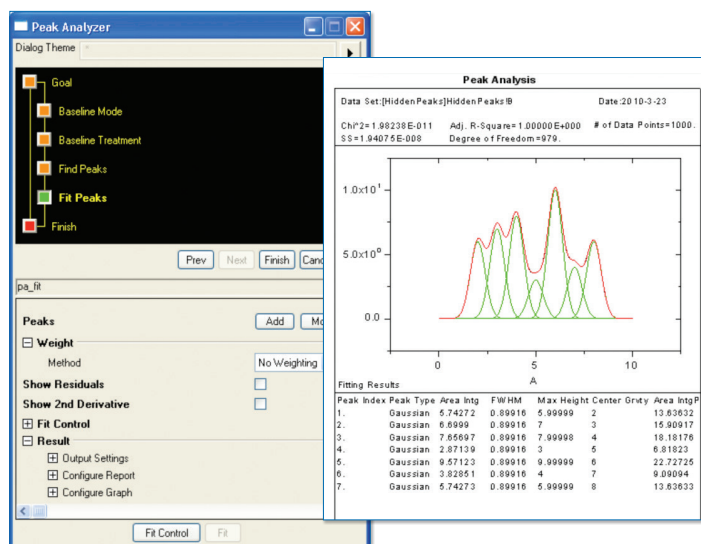

Multi-peak fitting with a detailed report

Peak Fit Control PRO

When using the Peak Analyzer to fit peaks, many options are available to customize your analysis.

- Add, delete or adjust the position of peaks directly on the graph
- Assign the same fitting function to all peaks, or use different fitting functions for each peak, or group of peaks
- Fix peak parameters to a constant value
- Share parameters across peaks
- Apply bounds and linear constraints to fitting parameters
- Plot residuals and second derivative of the fit curve
- Use over 20 built-in peak functions—including Gauss, Voigt, and Lorentz—or create your own

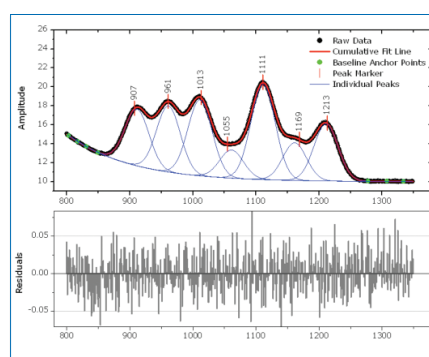

Control the fitting process directly on the graph

With the Peak Fit Parameters dialog, you have full control of the fitting parameters

Share a common parameter between peaks, fix the value of any parameter, or apply bounds. Right-click on a parameter value to share it with other peaks in the fitting operation

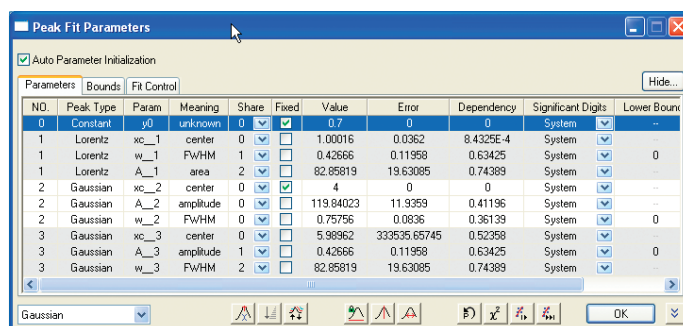

Fitting a Baseline PRO

OriginPro not only fits peaks, but can fit a function to your baseline data as well. The following options allow flexibility in fitting your baseline:

- Select baseline anchor points, or have Origin automatically find them
- Fit baseline anchor points using a pre-defined fitting function, or create your own
- Fix the baseline anchor points, or allow them to vary with the peak fit
- Subtract the baseline prior to fitting peaks

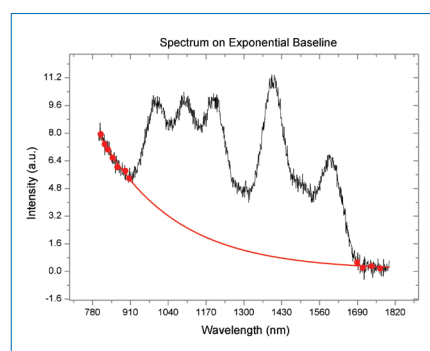

Fit a baseline to an exponential function using anchor points

"When the signal is small compared to the baseline noise, baseline subtraction is tough. In Origin, it was incredibly easy to create a test baseline (picking anchor point manually by clicking on the graph). Once we found the best baseline, we could process multiple data sets automatically. You just can't do this with any other software."

Rosina Georgiadis, Associate Professor, Chemistry Department, Boston University

Quick Peaks Gadget

The Quick Peaks Gadget provides a simple and quick way to perform peak analysis of plotted data within a ROI.

With this gadget, you can:

- Locate positive and negative peaks
- Define baseline and subtract from the spectrum
- Integrate peaks within base markers
- Perform peak fitting with frequently used functions
- Create a report sheet with parameters from each peak
- Repeat analysis on all curves in graph layer/page

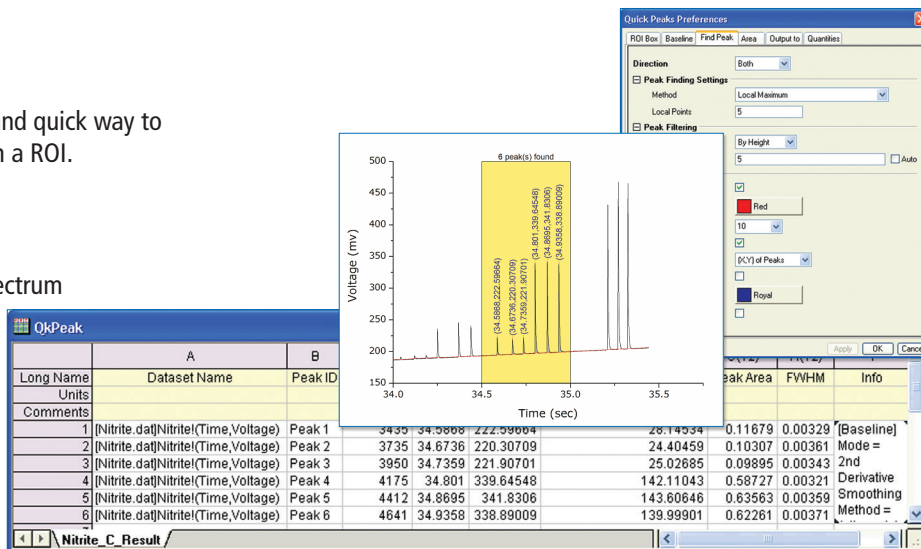

Create baseline, find Peaks, integrate peaks and output results

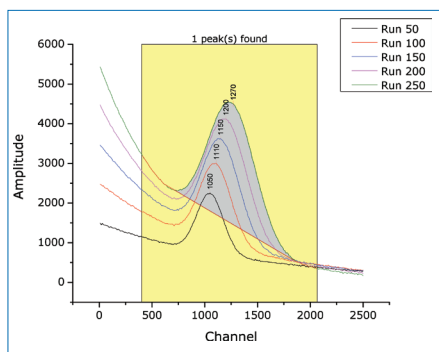

Batch Peak Integration on multiple curves.

Long Name	Dataset Name	Peak X	Peak Y	Height	Peak Area	FWHM
1 [Book1]Sheet1!(Channel,Run 50)		1050	2256.26	1448.87	427194.41	281.24
2 [Book1]Sheet1!(Channel,Run 100)		1110	3001.70	1886.80	663346.59	337.59
3 [Book1]Sheet1!(Channel,Run 150)		1150	3622.68	2281.05	911256.43	390.05
4 [Book1]Sheet1!(Channel,Run 200)		1200	4120.82	2687.46	1.23E+06	444.26
5 [Book1]Sheet1!(Channel,Run 250)		1270	4503.64	3047.02	1.56E+06	492.52

Plot multiple curves, use the Quick Peaks Gadget to set preferences such as baseline on one curve, then generate a report.

Batch Peak Fitting PRO

With batch peak fitting, OriginPro can handle many datasets, each containing multiple peaks.

- Perform batch peak fitting using a pre-defined theme, an Analysis Template™, or script
- Output a custom report of peak parameters for each peak in each dataset

Dataset Name	Peak Index	Peak Type	Area Fit	Area FIT	Area FITP	Center Max	Center Grvty	Max Height	FW
XJ-406 Trial #2	1	Gaussian	56.1634	37.25856	17.6942	6.65458	6.65458	1.67753	31.45
XJ-406 Trial #2	2	Gaussian	149.20413	149.11429	70.81483	25.61793	25.61793	8.33608	16.81
XJ-406 Trial #2	3	Gaussian	6.67886	4.03902	1.91814	38.18798	38.18798	0.10413	60.2
XJ-406 Trial #2	4	Gaussian	29.0945	20.15742	9.57282	47.26143	47.26143	2.13561	12.79
SJ-581 Trial #7	1	Gaussian	60.34625	60.34158	100	20.045	20.045	4.7823	11.89
AD-679 Trial #3	1	Gaussian	4.36173	2.94201	16.17467	6.52203	6.52203	0.14271	28.71
AD-679 Trial #3	2	Gaussian	14.69009	14.68398	80.72953	25.94682	25.94682	0.84512	18.32
AD-679 Trial #3	3	Gaussian	1.73372	0.56309	3.0958	52.98028	52.98028	0.10544	15.44
LP-215 Trial #1	1	Gaussian	155.46256	112.86122	30.09914	4.99583	4.99583	9.32322	15.6
LP-215 Trial #1	2	Gaussian	0.10299	0.10299	0.02747	8.25062	8.25062	0.03736	2.58
LP-215 Trial #1	3	Gaussian	30.8482	30.8482	8.22668	13.99901	13.99901	4.9718	5.82
LP-215 Trial #1	4	Gaussian	28.94503	28.94503	7.71914	26.0014	26.0014	4.98338	5.44
LP-215 Trial #1	5	Gaussian	15.86715	15.86715	4.23149	29.00948	29.00948	2.08907	7.13531
LP-215 Trial #1	6	Gaussian	10.65875	10.65875	2.8425	33.98893	33.98893	1.91434	5.23064
LP-215 Trial #1	7	Gaussian	235.78533	175.69411	46.85458	43.00029	43.00029	8.86134	24.99683

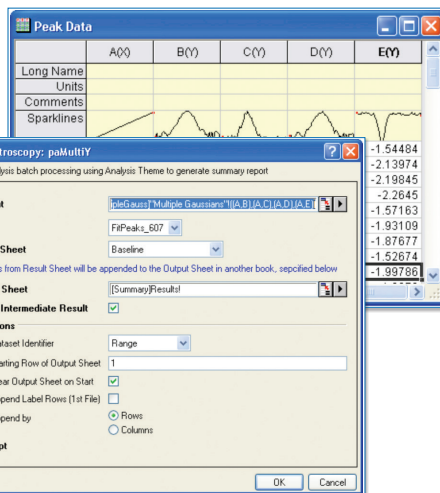

Perform peak fitting on multiple datasets using a pre-defined theme; output the results to a customized worksheet

Signal Processing

Signal Transforms

Origin provides several transform methods used for analyzing digital signals.

- Fast Fourier Transform and Inverse Fast Fourier Transform (FFT/IFFT)
- Short-time Fourier transform (STFT) **PRO**
- Hilbert Transform **PRO**
- 2D FFT/2D IFFT **PRO**
- Image Profiling: Simple Line Profiling: Horizontal, Vertical, Straight Line

Filtering

- FFT Filter:
 - Low Pass, High Pass, Band Pass, Band Block, Noise Threshold
- IIR Filter Design **PRO**
 - Butterworth, Chebyshev Type I, Chebyshev Type II, Elliptic
- 2D FFT Filter **PRO**

Smoothing

Origin offers multiple methods to smooth data

- Savitzky-Golay
- Adjacent-Averaging
- FFT Filter
- Percentile Filter
- Lowess and Loess

Correlation

Origin supports 1D and 2D correlation to detect the correlation between a pair of signals

- Correlation
- 2D Correlation **PRO**

Convolution/Deconvolution

Two types of Convolution and deconvolution are supported

- Linear
- Circular

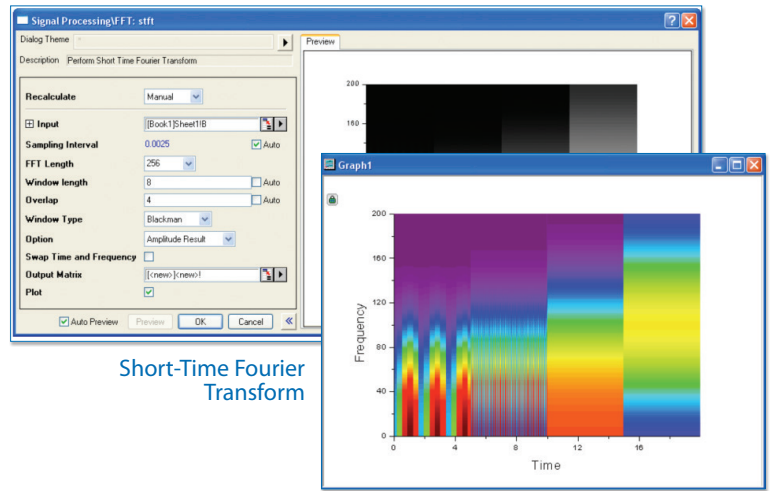

Short-Time Fourier Transform

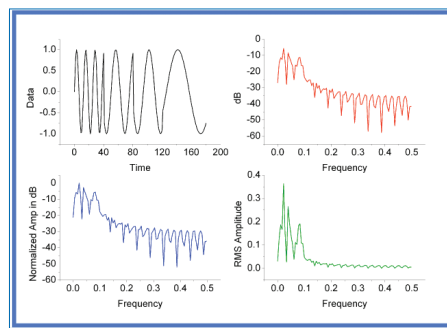

Results of FFT, including original signal and results in frequency domain

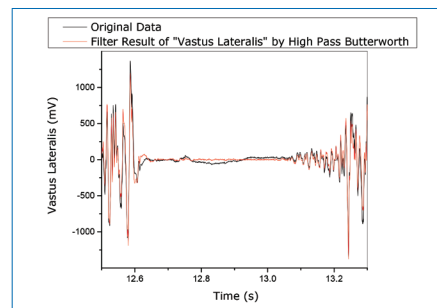
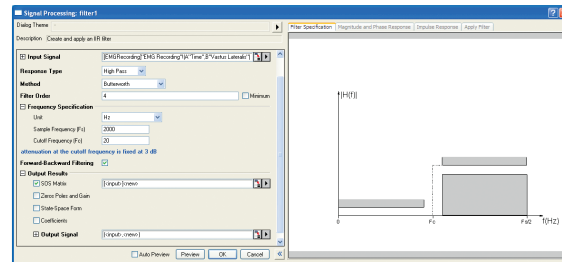

IIR Filter Design Dialog and Result

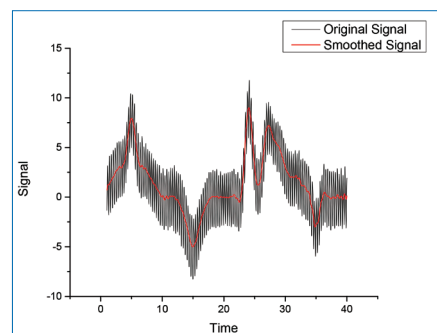

Smoothing

Wavelet Analysis **PRO**

Wavelet Transforms are used in many applications, including data compression, signal smoothing, noise removal, and image analysis. Wavelet analysis tools include:

- Continuous Wavelet Transform
- Discrete Wavelet Transform
 - (Decomposition)
- Inverse Discrete Wavelet Transform
 - (Reconstruction)
- Multi-Scale Wavelet Decomposition
- Smoothing
- Noise Removal
- 2D Wavelet Decomposition
- 2D Wavelet Reconstruction

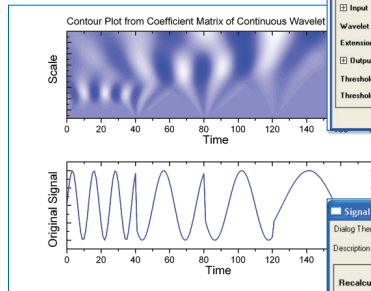

Continuous Wavelet Transform

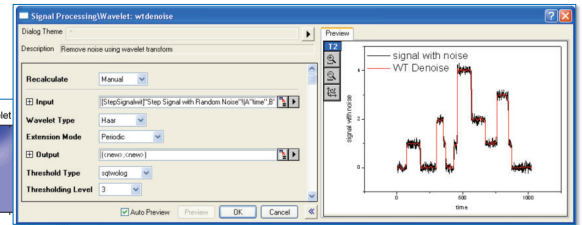

Remove Noise Using Wavelet Transform

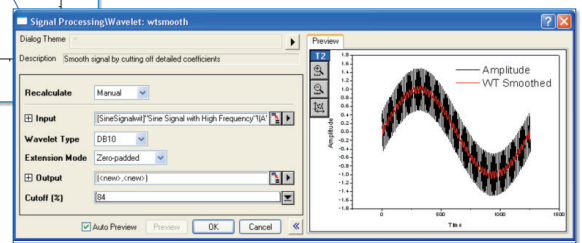

Wavelet Smoothing

Rise Time Gadget **PRO**

Three methods of finding the rise/fall time are supported:

- Linear search
- Histogram
- Largest triangle
- Select a specific region of the signal by moving and resizing a region of interest (ROI)
- Easily select desired data plot from the graph layer with multiple plots
- Display low and high levels inside the ROI control
- Display rise/fall time and rise/fall range on top of ROI

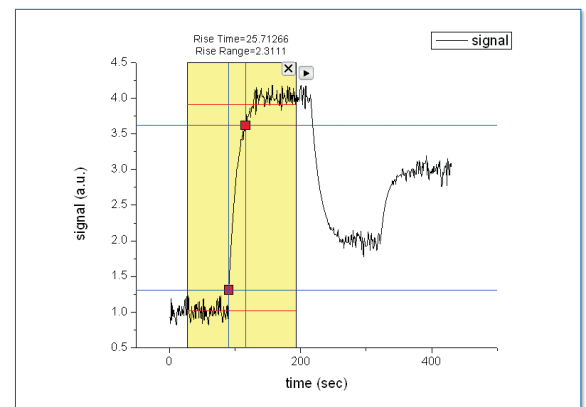

Rise Time Gadget

Decimation **PRO**

Decimation is used to reduce the number of elements in an input sequence. Every N samples are merged into one. Two filters are available:

- Moving Average
- Finite Impulse Response (FIR)

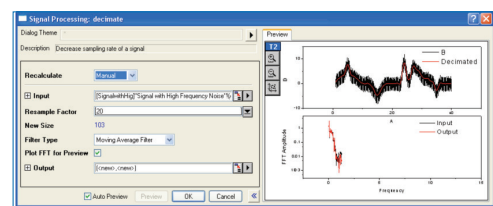

Decimation on Signal with High Frequency Noise

Coherence **PRO**

Coherence—the degree of linear dependency of two signals—is evaluated by testing whether the signals contain similar frequency components.

Envelope Curves **PRO**

An envelope curve traces the crests and troughs of a periodic signal.

- Choose upper, lower or both
- Smoothing option during envelope detection

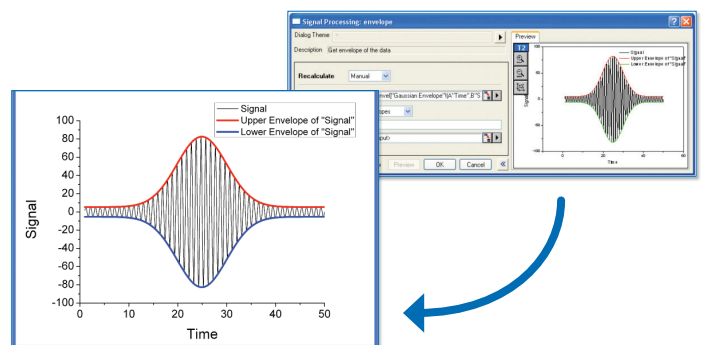

Envelope Curves

Statistics

Descriptive Statistics

Origin provides tools to help you summarize your continuous and discrete data:

- Statistics on Columns
- Statistics on Rows
- Cross Tabulation **PRO**
- Frequency Counts
- 2D Frequency Count/Binning
- Discrete Frequency
- Normality Test
- Distribution Fit **PRO**
- Correlation Coefficient **PRO**
- Partial Correlation Coefficient **PRO**

Parametric Hypothesis Tests

Seven hypothesis tests for mean and variance are available:

- One-Sample t-Test
- Two-Sample t-Test
- Pair-Sample t-Test
- Two-Sample t-Test on Rows **PRO**
- Pair-Sample t-Test on Rows **PRO**
- One-Sample Test for Variance **PRO**
- Two-Sample Test for Variance **PRO**
- One-Sample Proportion Test **PRO**
- Two-Sample Proportion Test **PRO**

ANOVA

Origin provides 5 ANOVA tools to examine the variance of a dependent variable:

- One-Way ANOVA
- Two-Way ANOVA
- Three-Way ANOVA **PRO**
- One-Way Repeated-Measures ANOVA **PRO**
- Two-Way Repeated-Measures ANOVA **PRO**

Survival Analysis **PRO**

Choose from three widely used survival analysis functions:

- Kaplan-Meier product-limit estimator, with three equality test methods
 - Log-rank
 - Breslow
 - Tarone-Ware
- Cox Proportional Hazards Model
- Weibull Fit Model

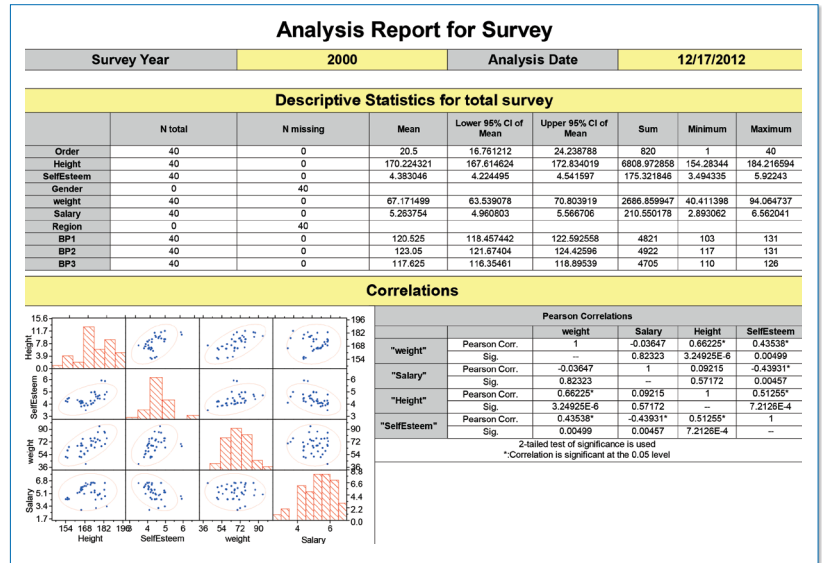

Custom report to automate your statistical analysis tasks

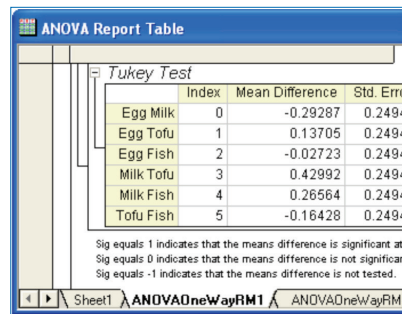

Means-comparison table, means plot, and mean-comparison plot in an ANOVA report

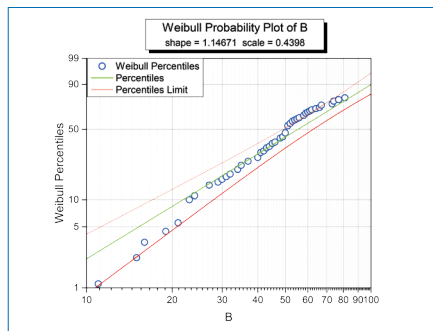
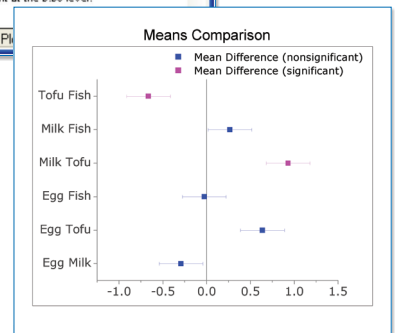
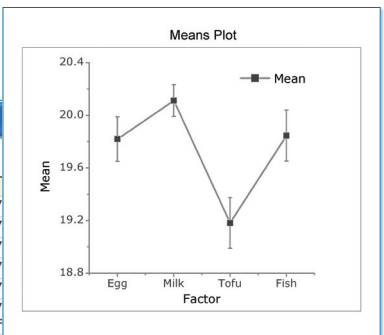

Survival Function Plot and Probability Plot of Weibull Fit

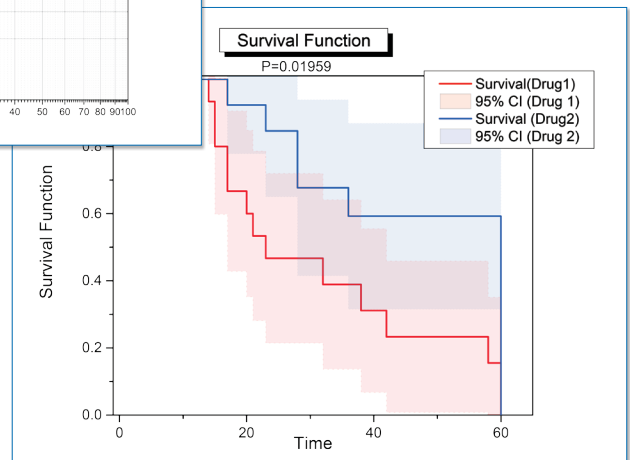

“OriginPro provides a very powerful, comprehensive and useful range of statistics capabilities which go beyond what is offered in many statistical packages. OriginPro’s ANOVA techniques include all important multiple comparisons tests for means, and a very useful output feature which is rarely found in other statistical packages: automatic creation of means comparison plots which will illustrate significant differences at a glance. A broad range of non-parametric tests is available which include the option of calculating exact p-values based on the exact distribution instead of the asymptotic one, which is very important for small sample size. Also sample size and power calculations are supported.”

Reinhard Bergmann, PhD, Novartis Institutes for Biomedical Research

Nonparametric Tests **PRO**

Several nonparametric tests are available, including:

- One-Sample Wilcoxon Signed Rank
- Paired-Sample Sign
- Paired-Sample Wilcoxon Signed Rank
- Two-Sample Kolmogorov-Smirnov
- Mann-Whitney
- Kruskal-Wallis ANOVA
- Mood’s Median
- Friedman ANOVA

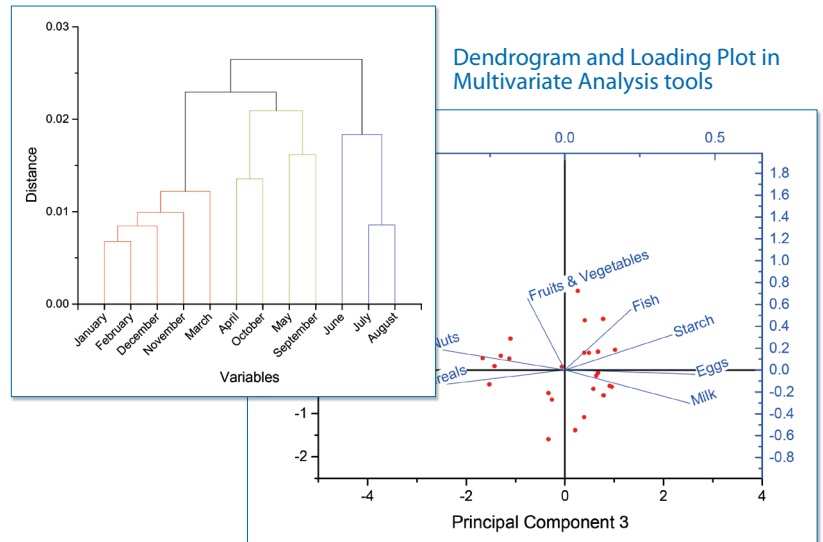

Multivariate Analysis **PRO**

Five commonly used multivariate tools are available:

- Principal Component Analysis
- K-Means Cluster
- Hierarchical Cluster
- Discriminant Analysis
- Partial Least Square

ROC Curves **PRO**

Create Receiver Operating Characteristic (ROC) Curves, summarizing the trade-off between the false-positive and true positive rates for all possible cutoff values.

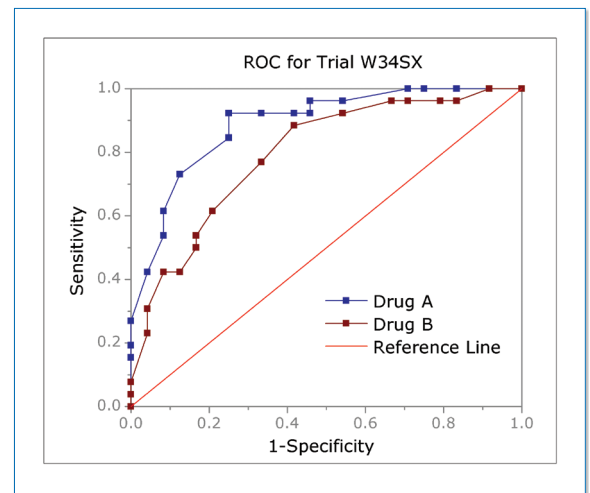

ROC curve comparing two samples

Power and Sample Size **PRO**

- One-Sample t-Test
- Two-Sample t-Test
- Pair-Sample t-Test
- One way ANOVA
- One-Proportion Test
- Two-Proportion Test
- One-Variance Test
- Two-Variance Test

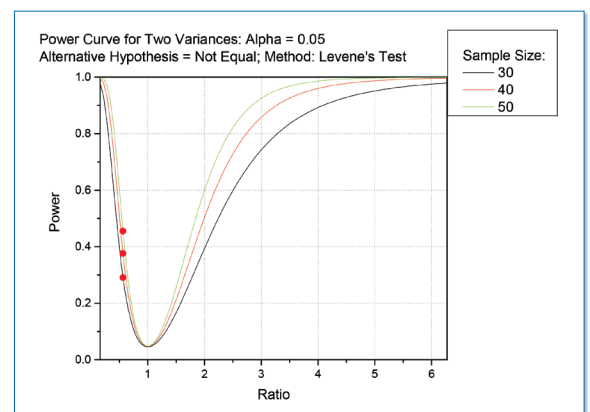

Handling Repetitive Tasks

Graph Template

Templates allow you to quickly create consistent-looking graphs. They also provide a starting point for creating your own set of graph customizations.

Graph Theme

Graph themes can be applied to any graph at any time, thus changing various object properties such as layer size, page color, plot symbol type and color.

Copy and Paste Formats

Copy and paste formatting from one plot to another, to quickly set properties of individual elements or all objects in the graph.

Batch Plotting

Origin supports batch plotting. If you have several workbooks, worksheets or columns with similar data, you can create one graph and then duplicate that graph using other data.

- Duplicate graph with new sheets/books
- Duplicate graph with new columns

Smart Plotting with Cloneable Graph Templates

Worksheet column to graph layer associations are saved in template, allowing for one-click creation of graphs from sheets with similar data structure.

- Mark a graph template as Cloneable Template
- New Template Library for User-defined Graph Templates only

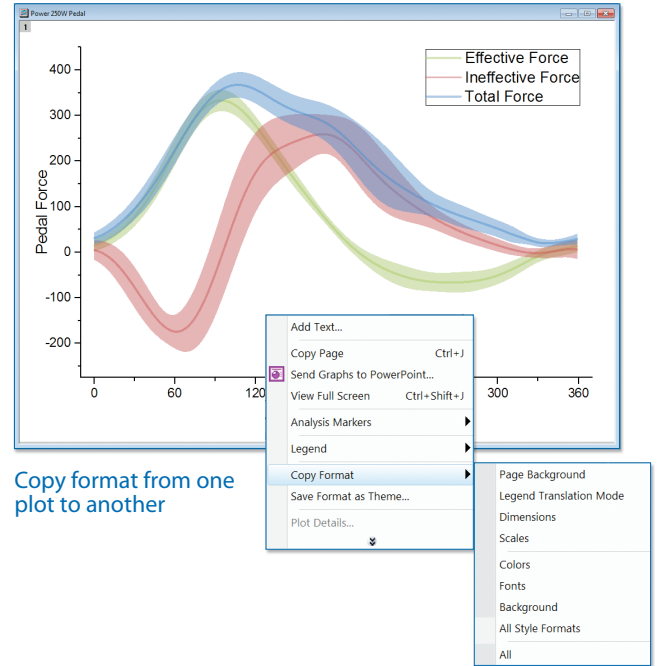

Copy format from one plot to another

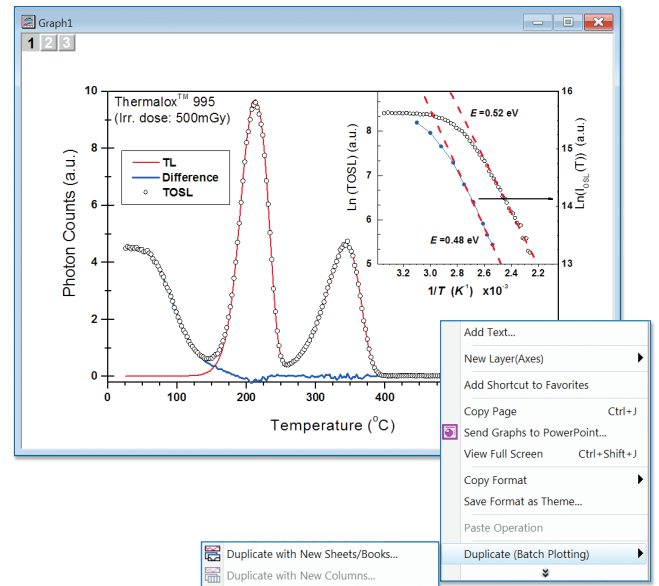

Long Name	Year	Make	Weight	0-60 mph
Units			kn	sec
1	1992	Buick	2238	14
2	1992	Acura	2324	12
3	1992	GMC	1831	13
4	1992	Chrysler	2088	10
5	1992	Kia	1202	12

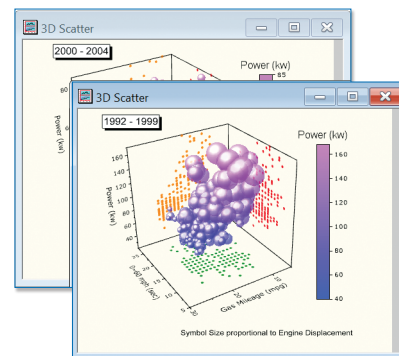

Recalculation of Analysis Results

Origin supports automatic or manual recalculation of results for most analysis and data processing operations.

This allows you to:

- Perform the same analysis on other datasets by replacing data
- Update existing results by changing analysis parameters

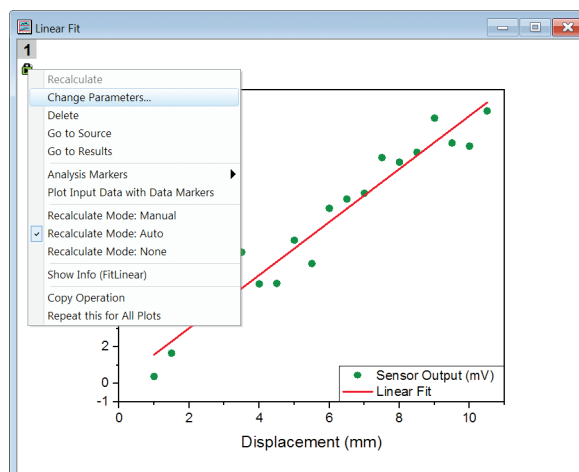

The “Change Parameters...” menu item allows you to re-open a dialog and change analysis parameters to update the analysis

Clone Workbook during Batch Import

Origin provides a quick yet powerful way to allow user perform batch analysis when importing multiple files.

- Import one file and set up your workbook with desired analysis and graphs all contained within the book
- Import a set of new files, and simply ask for the active workbook to be cloned for each new file

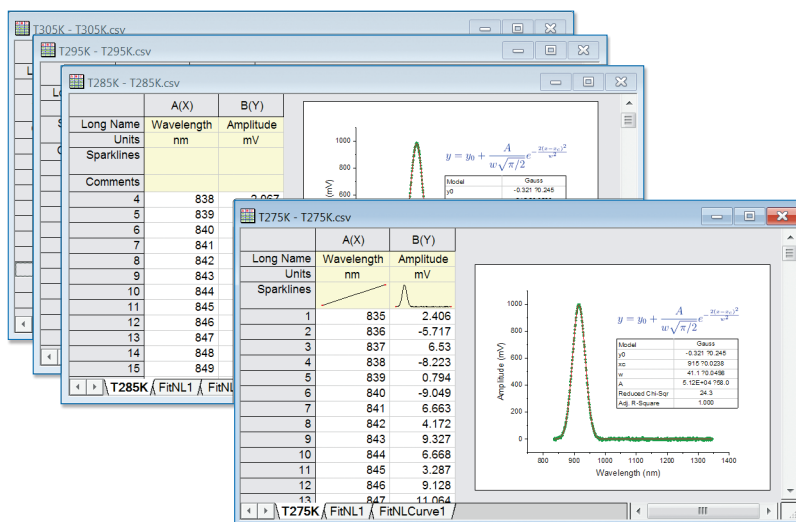
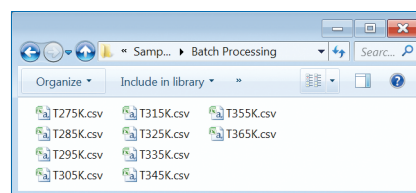

Import multiple data files into cloned workbooks to perform batch processing

Handling Repetitive Tasks *(continued...)*

Repeat Operation on All Plots or Columns

Once you perform an operation on a data plot or a worksheet column, Origin allows you to repeat that operation for all other plots in the graph, or all other columns in the worksheet.

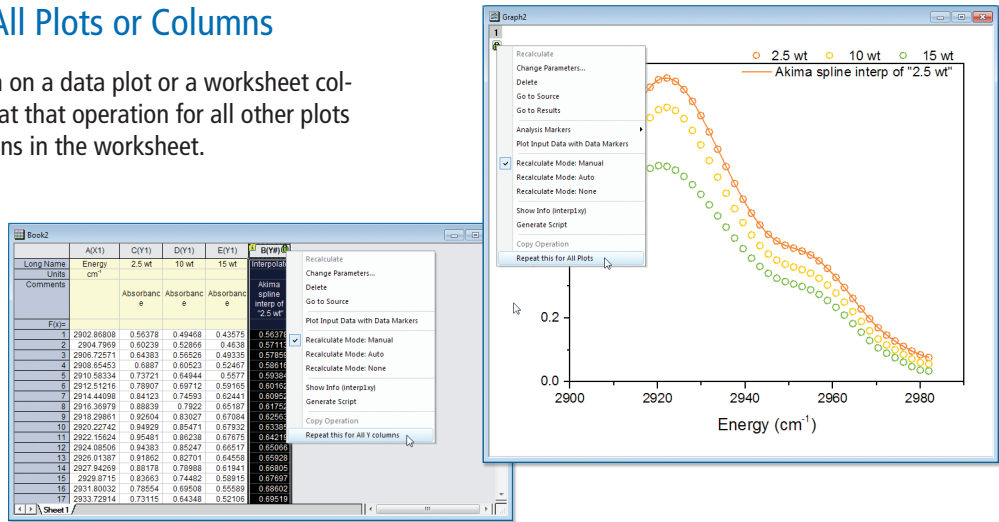

Copy & Paste Fitting Operation

Once you perform curve fitting on one data plot, you can simply copy and paste that operation on other selected curves in the same graph or on other graphs.

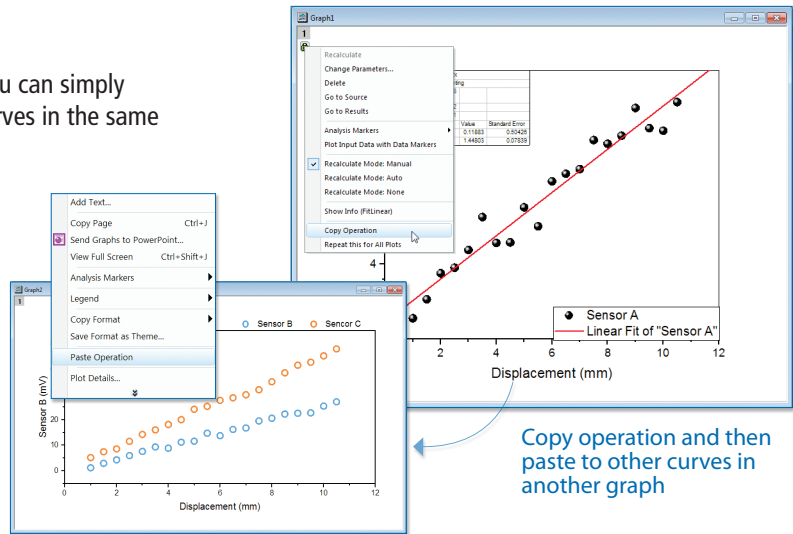

Copy operation and then paste to other curves in another graph

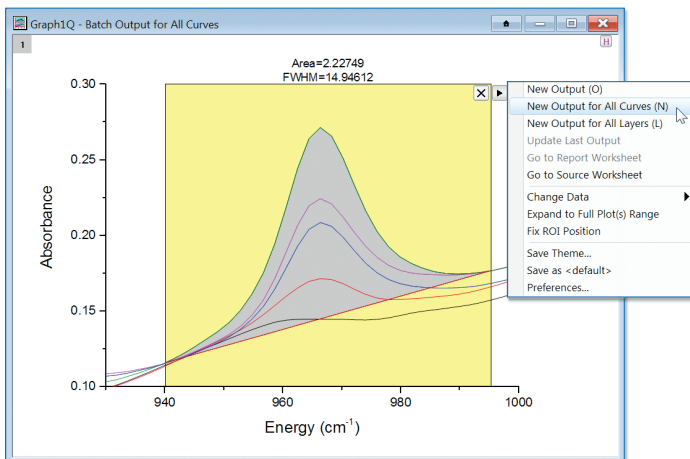

Use Gadgets for Analyzing Multiple Curves

Origin supports performing repetitive analysis on multiple data plots using Gadgets.

Analysis Templates™

Origin's ability to recalculate results on parameter or data change, can be used to create Analysis Templates™ for repeat analysis.

Analysis Templates™ can be a single workbook or an entire Origin project. Import data, perform analysis, and optionally create a custom report sheet combining graphs and results. Save the book or project as an Analysis Template™, and then re-use to analyze similar data.

Set up your analysis the way you want. After your initial analysis has completed, just save the workbook as an Analysis Template™

Long Name	A(X)	B(Y)
Units	nm	mV
Comments		
Sparklines		
1	835	2.406
2	836	-5.717
3	837	6.53
4	838	-8.223
5	839	0.794
6	840	-9.049
7	841	6.663
8	842	4.172
9	843	9.327
10	844	6.668

Value	Standard Error		
y0	-0.32072	0.24543	
xc	915.09771	0.02384	
w	41.05354	0.04978	
Amplitude	A	51177.36936	58.02025
	sigma	20.52677	0.02489
	FWHM	48.33685	0.05861
	Height	994.6433	1.01537

Batch Processing

Origin provide several options to allow you to process multiple files or datasets and create summary reports, from the GUI without programming.

- Repeat analysis on multiple files/datasets using an existing Analysis Template™
- Create summary report by appending rows with desired information for file/dataset
- Link Analysis Template to a Microsoft Word template for report creation
- Import multiple files into sequential worksheets in your Analysis Template™
- Execute LabTalk script before or after each file, or at end of the batch process

Files...

Analysis Template...

Batch Report

File Name	Peak Center	Peak Width	Stat Width	FWHM	Peak Area	Peak Height
T275K.csv	915.10	41.05	20.53	48.34	51177.37	994.64
T285K.csv	945.89	43.36	21.68	51.05	53294.14	980.78
T295K.csv	977.53	45.97	22.98	54.12	55294.71	959.82
T305K.csv	1009.93	48.03	24.01	57.72	57648.89	937.70
T315K.csv	1043.14	52.17	26.08	61.62	59468.89	908.63
T325K.csv	1077.12	55.89	27.95	65.81	60988.73	873.31
T335K.csv	1113.88	59.75	29.87	70.35	62487.42	834.50
T345K.csv	1147.47	63.93	31.97	75.28	63458.07	795.41
T355K.csv	1183.86	68.57	34.29	80.74	63700.12	743.19
T365K.csv	1221.06	73.40	36.70	86.42	63447.02	689.69

Custom Reports

Use Origin to perform repetitive analysis and create custom reports without any programming.

Origin's new multi-sheet workbooks allow you to format the appearance of cell contents, merge cells and apply borders and other formatting changes. Further, you can paste-link result values from any analysis results and graphs contained in the book or project, thus creating a custom report sheet. With the ability of automatic recalculation of analysis results, your custom report sheets can become templates for repeated tasks—simply import new raw data and watch your custom report automatically update. When your report is ready, export it as a PDF file or as an image file by choosing a popular image format such as EPS and JPEG.

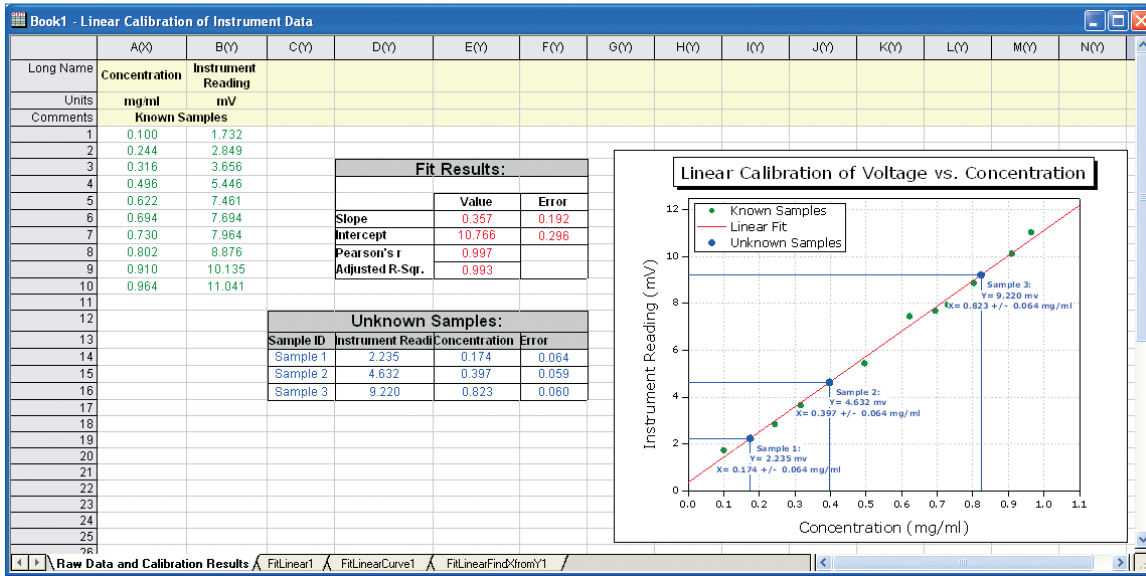

Include data, analysis results and floating graphs in the custom report sheet, it will automatically update when input data is changed

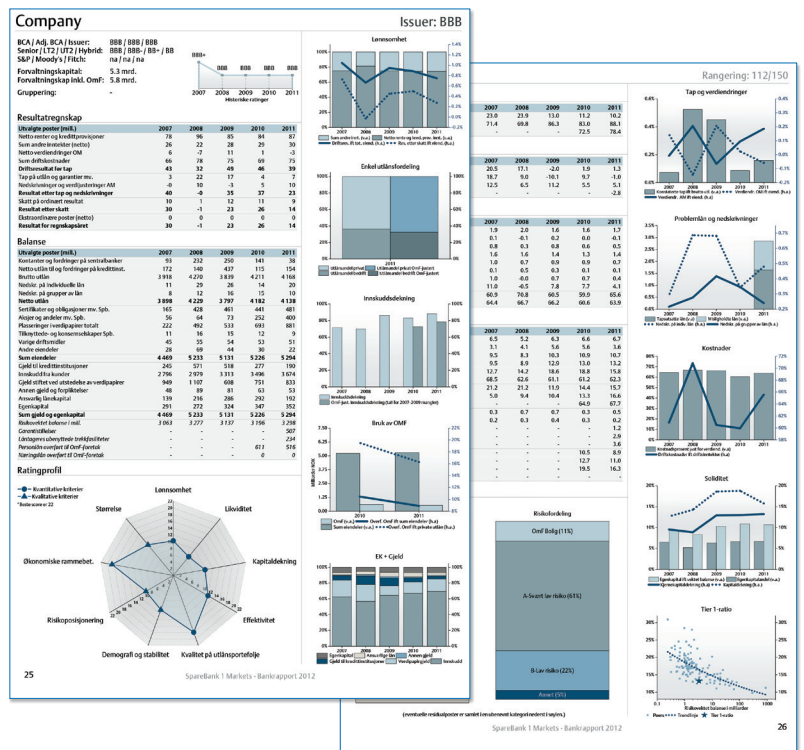
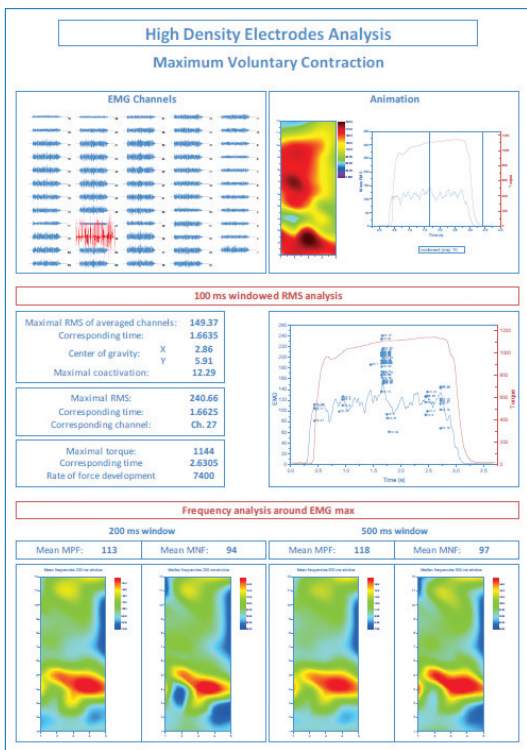

Numerical results, graphs, company logo and other images can all be placed arbitrarily in worksheets to create single or multi-page reports which can then be exported

Publishing

Origin provides a number of tools for preparing files for publication and presentation. Graphs, Worksheets, and Layout pages can be exported with custom settings for publication. Use Origin's built-in slide show capability to present graphs and layout pages, or send to PowerPoint, or copy-paste into other applications. Export graphs, layouts, and worksheets as vector or raster format for submitting to publications.

Exporting Graphs

When you have completed your graph for publication, exporting your final result is very easy with Origin.

- Export presentation quality graphs to a wide variety of formats, including both raster and vector format
- Customize the exporting, to make figures that meet the requirements of publication under a variety of circumstances
- Export graphs to a Microsoft® PowerPoint Slideshow or send graphs directly to a Microsoft PowerPoint presentation

Note that you can also include Origin graphs in other application's files either by pasting or embedding, so that you can later edit these graphs with Origin.

Creating Movies

Origin supports creating movies (AVI file format) from any graph window. A simple tool is provided to configure settings such as compression, and then add individual frames to create the movie. The LabTalk and Origin C programming environments can also be used to create movies, allowing users to integrate movie creation as part of their data processing or computing tasks.

Publishing Custom Reports

Custom reports created by placing numerical results and graphs in an Origin worksheet can be exported as image files. Vector formats such as PDF and raster formats such as PNG are both supported. Reports that occupy more than one page can be exported as multi-page PDF files.

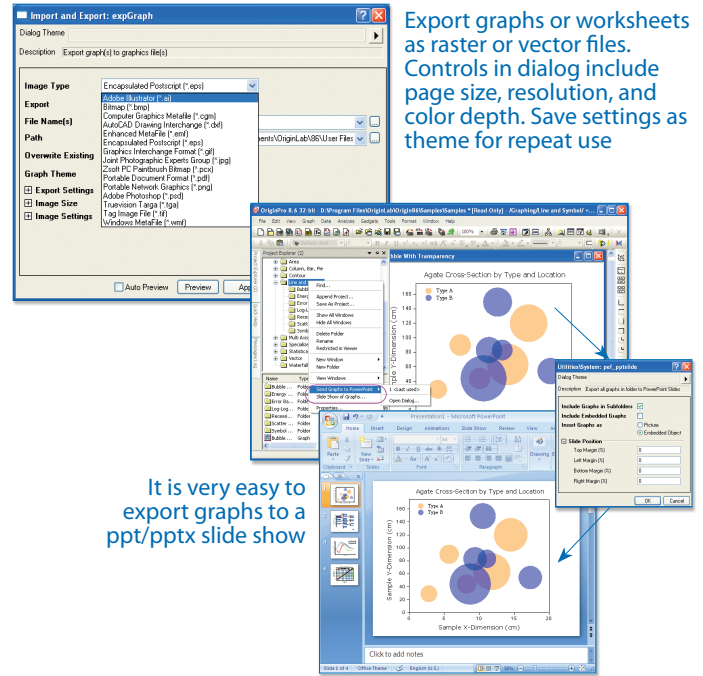

It is very easy to export graphs to a ppt/pptx slide show

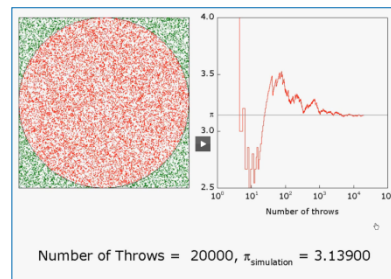

Movie displaying value of pi being computed using Monte Carlo method

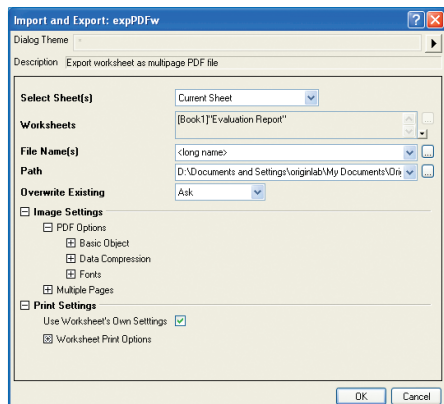

When publishing your custom report, use the PDF export dialog to control font-handling, color translation mode, resolution and compression, page numbering scheme, and other options

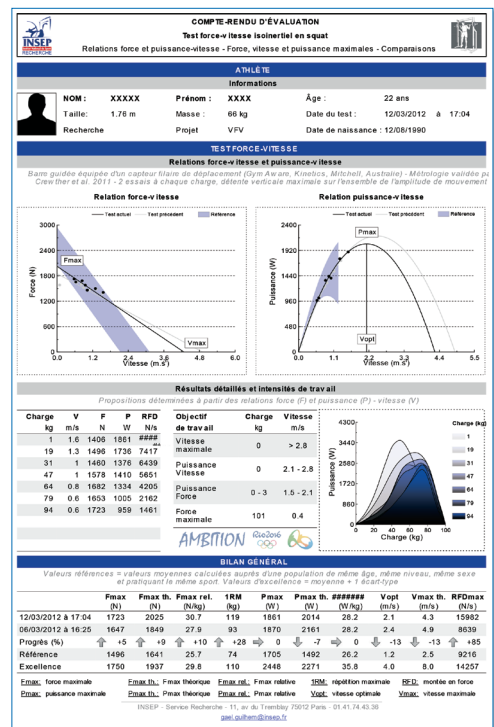

Working with Excel®

Origin provides easy access to your Excel data:

- Copy-paste data from Excel to Origin with full precision
- Import Excel files into Origin worksheets keeping cell formatting and specifying header rows
- Open Excel workbooks directly in Origin
- Optionally save Excel workbooks open in Origin with path relative to the Origin Project (OPJ) file, for easy sharing of OPJ and related Excel files

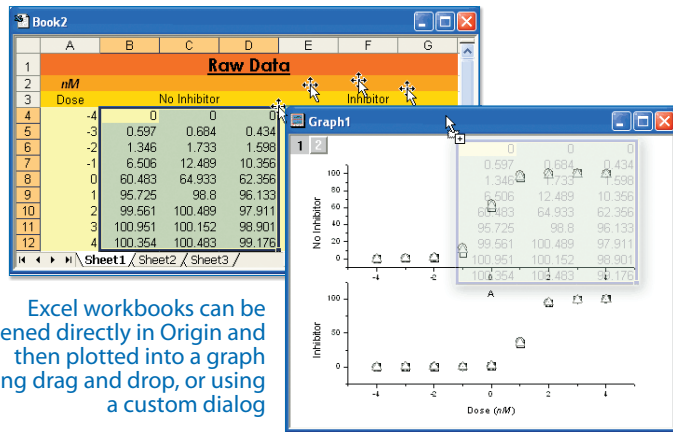

Importing Excel Files, keeping cell formatting, and specifying which rows to treat as header

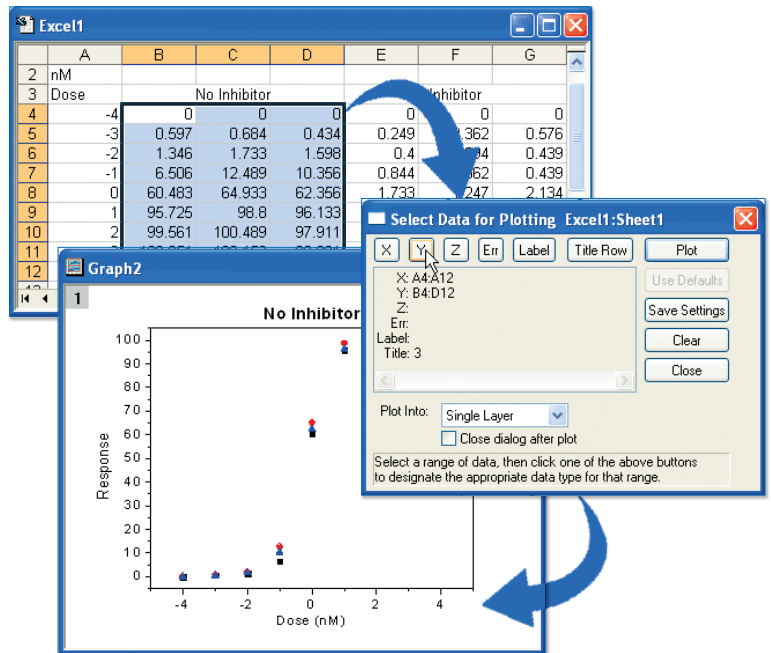

MATLAB® Connectivity

Importing MATLAB® Files

Origin offers a dialog for importing MATLAB (.mat) files into Origin worksheets and matrices. This import functionality does not require MATLAB to be installed.

MATLAB® Console

If you have MATLAB installed, you can use the Console tool to issue MATLAB commands from within Origin. Buttons and commands are also provided to transfer data from the MATLAB workspace to Origin, and to create MATLAB variables from data in Origin worksheet and matrices.

LabVIEW™ Connectivity

Origin provides a collection of custom LabVIEW sub-VIs that are included in the installation. LabVIEW users can incorporate these custom sub-VIs in their main LabVIEW application to communicate seamlessly with Origin. These sub-VIs take advantage of Origin's automation server classes and can be used for operations such as opening and closing communication with Origin, exchanging data between Origin and LabVIEW, and sending commands to Origin.

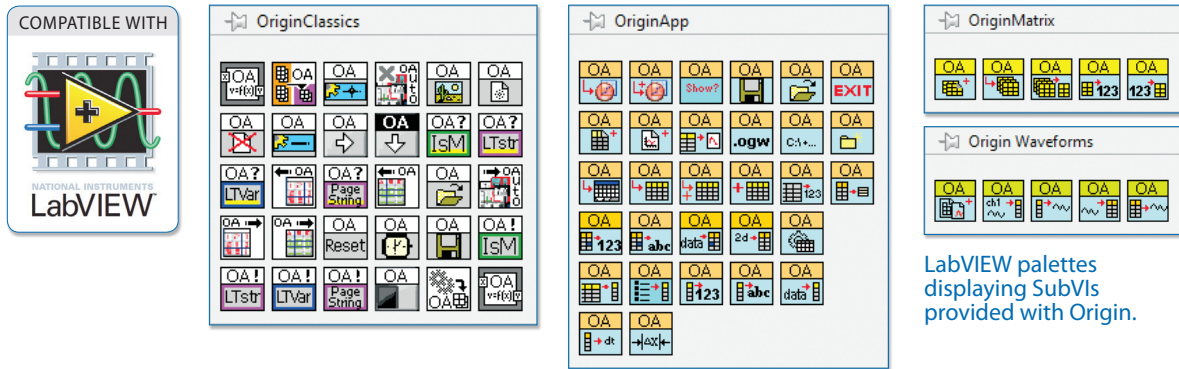

LabVIEW palettes displaying SubVIs provided with Origin.

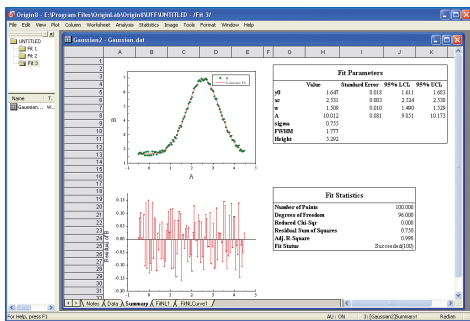
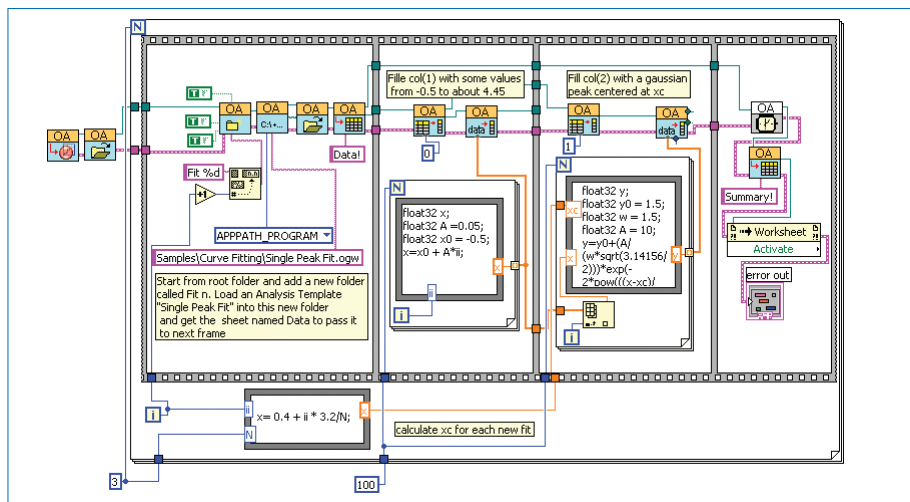

The VI diagram above demonstrates an example of how to perform batch analysis of multiple datasets using an Analysis Template™ in Origin.

In this example, the experimental data has been fitted to a Gaussian curve. The fitted curve, residuals and fit statistics are presented in a user-created report sheet.

Once the VI has executed, the Origin project will have separate subfolders for each dataset. Within each subfolder the Analysis Template™ will contain the raw data, the analysis results, and the custom report sheet ready for printing or exporting.

“Origin can now really augment LabVIEW’s power. The drag-and-drop Origin sub-VIs that come with Origin are simple and easy to use. With Origin’s Analysis Templates™ it is now very simple to create a reusable application that acquires data from third-party instruments, and then passes the data for analysis and report generation to Origin. One can also get curve fit results back into LabVIEW to display in LabVIEW’s charts and graphs on the fly. What’s best is that this is all accomplished in a native LabVIEW environment.”

James T. Gardner, Ph. D., Chief Engineer, Environmental Instruments, Inc.

Programming

LabTalk

LabTalk is a scripting language native to Origin. For simple operations such as manipulating data and automating tasks, LabTalk is a good place to start. You can access a rich set of script commands and functions, including a large collection of X-Functions, to create scripts for your specific needs. Your custom script code can be easily assigned to buttons on graphs or worksheets, new toolbar buttons or custom menu items.

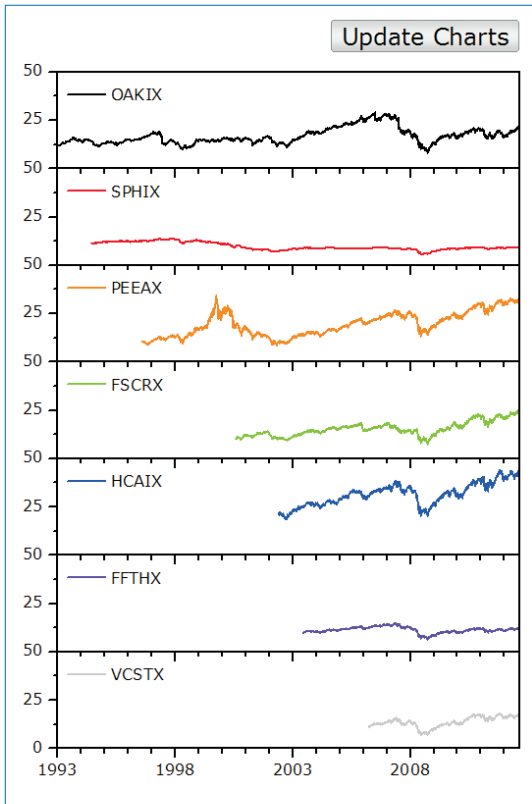

Origin C

Origin C is a programming language based on ANSI C, including additional support for C++ and C# features.

With Origin C, you can:

- Create and access properties of all Origin objects such as worksheets, matrices and graphs
- Automate your data analysis and graphing tasks
- Link to external dynamic link libraries (DLL)
- Call C or Fortran library routines, such as the NAG library functions included with Origin, or other public-domain libraries

Origin provides a state-of-the-art integrated development environment called Code Builder for managing your Origin C projects.

Python

Origin provides an embedded Python environment so that you can either run Python in Origin, or use a PyOrigin module to access Origin from Python.

```
Script Window
File Edit Help Tools
Function string strFind(dataset ds, string strVal)
{
    string strTest, strResult;
    for( int ii = 1 ; ii <= ds.GetSize(); ii++)
    {
        if (strTest.Find(strVal) > 0)
        {
            strResult$ = $(strResult$)%(CRLF)$(strTest$);
        }
    }
    return strResult$;
}

string MyResult$ = strFind(col(3), "hadron")$;
MyResult$;

Function int GetMinMax(range rr, ref double min, ref double max)
{
    stats rr:
    min = stats.min;
    max = stats.max;
    return stats.n
}

double y1, y2;
int nn = getminmax(1:end, y1, y2);
type "Worksheet has $(nn) points, min=$(y1), max=$(y2)";
```

Classic Script Window displaying LabTalk Script

The 'Programming Control' dialog box is shown with the following settings: Object Name: Text; Attach to: Page; Link to [%.\$]: Substitution Level 0; Script, Run After: Button Up; Ctrl-TAB for TAB. The script text in the dialog is: `// Call OGS file section to fetch new data
run.section(<Stocks, GetNewData);

// Call section to update report
run.section(<Stocks, UpdateReport);`

Origin graph with text label set up as button for executing LabTalk script. The dialog provides controls such as event handling, and the script to be executed on button-click

The screenshot shows the 'Code Builder' IDE with a C source file open. The code includes NAG library headers and defines a function for matrix multiplication. Below the code is a 'Variables' table:

Variable	Value
dCoh	2.352409E1543247
dk	1.5
nkMagEvec	1.1
code	0
env	0
message	"E_NODERROR! No error"
handler	Invalid Object
semant	0
flag	0
val	0

At the bottom, the 'Command & Results' window shows the execution of 'SimpleNAGEX 1.5'.

Origin C code displayed in Code Builder, Origin's integrated development environment

R

Origin provides R Console and support for Rserve to exchange data between Origin and R.

Building Dialogs

Create dialog boxes and custom interfaces using standard HTML, CSS and JavaScript. Embed Origin graphs with interactive controls such as cursors and ROI objects. Call JavaScript functions from Origin C and call Origin C methods from JavaScript.

Custom tools can be packaged with all associated files as an App. Simply drag-and-drop the App on an Origin installation to add the custom capability.

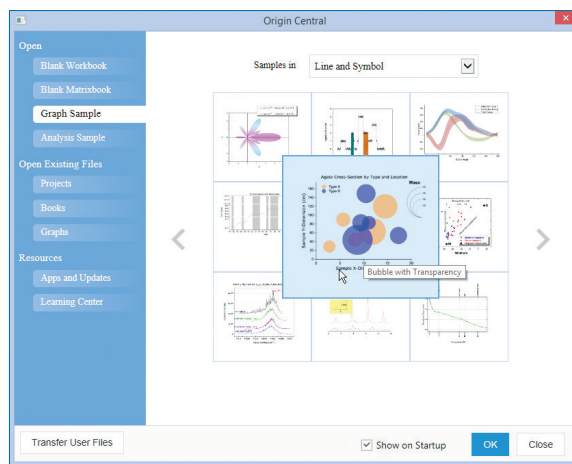

The "Origin Central" dialog is built using HTML and JavaScript

```
//this is the function to call JavaScript
BOOL GetGraphControlRect(RECT& rectGraph)
{
    if (!m_dhtml)
        return false;
    Object jscript = m_dhtml.GetScript();

    if(!jscript) //check the validity of returned COM object
        return false;

    string str = jscript.getGraphControlRect();
    JSON.FromString(rectGraph, str); //convert string to a structure
    return true;
}
```

Origin C code to call a JavaScript function

```
<script>
function getGraphControlRect()

    var leftDiv = document.getElementById("leftcontainer");
    var leftpos = leftDiv.getBoundingClientRect().right;
    var toppos = leftDiv.getBoundingClientRect().top;
    var bottompos = leftDiv.getBoundingClientRect().bottom;

    var rightDiv = document.getElementById("rightcontainer");
    var rightpos = rightDiv.getBoundingClientRect().left;

    return JSON.stringify({
        left: leftpos + 20,
        top: toppos + 20,
        right: rightpos - 20,
        bottom: bottompos - 20})
}
</script>
```

JavaScript function returning JSON string to Origin C



Origin/OriginPro includes the complete NAG Mark 9 numerical library. This library provides proven numerical functions in areas such as Statistics, Linear Algebra, Regression, Fourier transforms and much more. All functions are accessible from Origin C, and this allows you to develop complex applications that require advanced numerical calculations.

- Complex Arithmetic
- Zeros of Polynomials
- Roots of One or More Transcendental Equations
- Fourier Transforms
- Wavelet Transforms
- Quadrature
- Ordinary Differential Equations
- Partial Differential Equations
- Mesh Generation
- Interpolation
- Curve and Surface Fitting
- Minimizing or Maximizing a Function
- Global Optimization of a Function
- Linear Algebra
- Matrix Factorizations
- Eigenvalues and Eigenvectors
- Determinants
- Simultaneous Linear Equations
- Linear Algebra Support Functions
- Linear Equations (LAPACK)
- Least-squares and Eigenvalue Problems (LAPACK)
- Large Scale Linear Systems
- Large Scale Eigenproblems
- NAG Interface to BLAS
- Simple Calculations on Statistical Data
- Correlation and Regression Analysis
- Multivariate Methods
- Analysis of Variance
- Random Number Generators
- Univariate Estimation
- Nonparametric Statistics
- Smoothing in Statistics
- Contingency Table Analysis
- Survival Analysis
- Time Series Analysis
- Operations Research
- Sorting and Searching
- Approximations of Special Functions
- Mathematical Constants
- Machine Constants
- Input/Output Utilities

Programming

X-Functions

X-Functions provide a framework for building custom tools in Origin. Simply define what controls you want in your dialog and Origin will create the tool from your definition. You provide the Origin C code to be executed by the tool for performing your custom task. Once an X-Function is created, it can be placed in the Origin menu, accessed from LabTalk script, and shared with other Origin users.

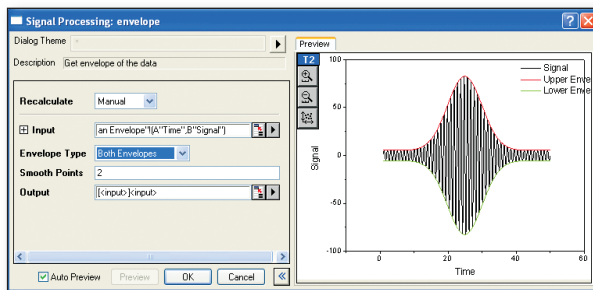
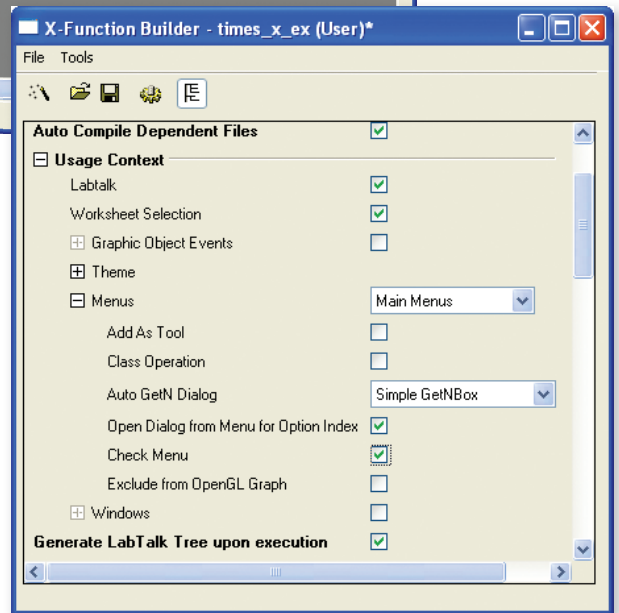
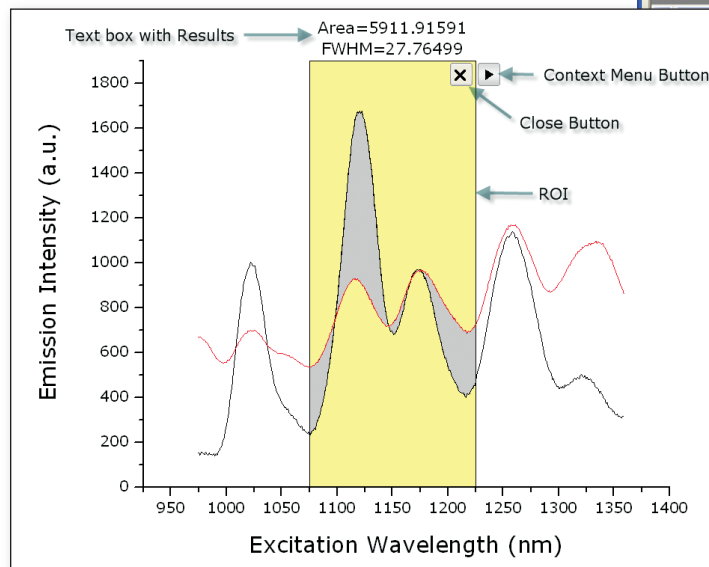
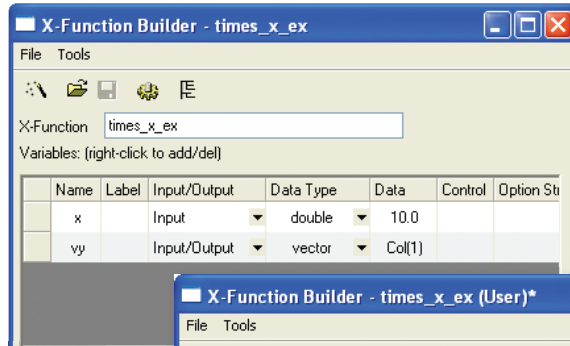

X-Function dialog with preview panel

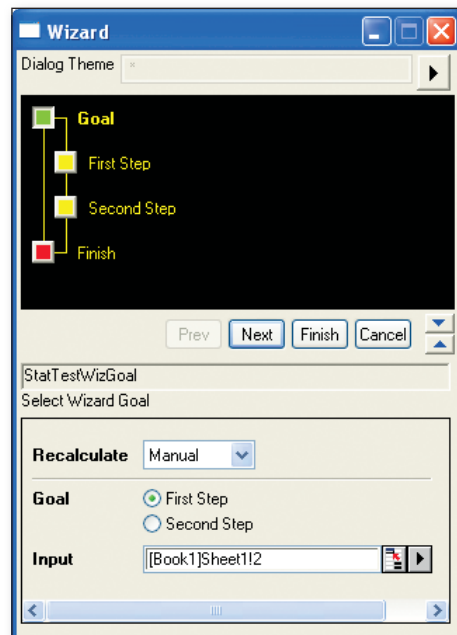

Wizard created with X-Functions

Automation Server

Origin can be accessed as an automation server from client applications such as Excel, LabVIEW, MATLAB, or custom tools built using Visual Basic® or Visual C++ .NET. Data can be streamed into Origin and graphed, and tools in Origin such as Gadgets can be used to perform analysis on the incoming data. Post analysis of data can also be performed by pushing data into Analysis Templates™.

This example illustrates connecting an Excel Client application to Origin:

- Origin is launched and a previously customized Origin Project is opened
- Data is sent from Excel to Origin
- Analysis results are automatically updated by Origin on data change
- Analysis results and graph images are fetched back to Excel from Origin

The screenshot shows a Microsoft Excel spreadsheet with two columns of data: 'Raw Data' and 'Output'. The 'Raw Data' column has 'X' and 'Y' values, and the 'Output' column has 'New X' and 'Interpolated Y' values. A graph titled 'Graph1' is visible, showing a curve fitted to the data points. A dialog box titled 'Connect Origin and Interpolate' is open, with buttons for 'Interpolate', 'Disconnect Origin', and 'Disconnect and Close Origin'. A VBA code window is also visible, showing the code for the 'Interpolate' button click event.

Raw Data	Output		
X	Y	New X	Interpolated Y
0.5	590	0.5000	590.0000
2	1190	0.9910	791.95463
4	1495	1.2820	949.24795
6	1630	1.6729	1096.09539
8	1740	2	1190
10	1810	2.4549	1263.99980
12	1860	2.8459	1352.90796
14	1895	3.2369	1407.01795
16	1935	3.6278	1450.2916
18	1940	4.0000	1495.0000
20	1960	4.4769	1519.3026
22		4.8008	1549.4068
24		5.1917	1577.2610
26		5.9027	1603.4958
28		5.9737	1628.3547
30		6.3647	1652.4499
32		6.7556	1675.5914
34		7.1466	1697.5343
36		7.5375	1718.0169
38		8.0000	1740.0000
40		8.31955	1753.618429
42		8.71923	1768.70981
44		9.1016	1782.349027
46		9.4648	1794.872936
48		10	1810
50		10.27444	1817.943621
52		10.66441	1828.68342
54		11.06639	1838.78643
56		11.44727	1848.10097
58		11.83835	1856.742723
60		12	1860
62		12.8003	1871.10117
64		13.01128	1877.512412
66		13.40226	1883.98925
68		13.79323	1890.46241
70		14	1895
72		14.02519	1907.53515

```

NOTE: ThisWorkbook.oApp is declared as public, in ThisWorkbook code
'Code for "Open Origin Analysis Template" command button
Private Sub CommandButton1_Click()
    'Check radio choice to see if user wants to launch new instance or try connecting
    'to an existing instance
    If (OptionButton1.Value) Then
        On Error GoTo ErrMsg1
        'Launch a new instance of Origin and connect to it
        Set ThisWorkbook.oApp = New Origin.Application
    Else
        On Error GoTo ErrMsg1
        'If an instance of Origin is already present, connect to it
        'otherwise launch a new instance and connect to it
        Set ThisWorkbook.oApp = New Origin.ApplicationSI
    End If
    'Successfully connected to Origin
    'Show/hide appropriate controls
    CommandButton2.Enabled = False
    CommandButton3.Enabled = True
    CommandButton4.Enabled = True
    'Make origin visible
    ThisWorkbook.oApp.Visible = MAINWND_SHOW
    'Load a specific Analysis template for performing the computation and graphing
    'see loading OPJ, give user chance to save current work if dirty flag is set
    (ThisWorkbook.oApp.IsModified) Then
        'Ask user to go to Origin, save the project, and come back to Excel
        MsgBox ("The project currently open in Origin needs to be saved" & vbCrLf & "Go to Origin and save the project if needed." & vbCrLf & "Click OK button below to continue.")
        'Reset the dirty flag, this is actually not needed since NewProject will reset it below
        'we never start a new project
        ThisWorkbook.oApp.IsModified = False
    End If
    'Loading of opj will append it, so to ensure proper book short name
    'we never start a new project
    ThisWorkbook.oApp.NewProject
    'Now load a sample Analysis template for performing the computation
    Dim strFile As String
    strFile = ThisWorkbook.Path & "\Interpolation.opj"
    If Not (ThisWorkbook.oApp.Load(strFile)) Then
        Dim strOut As String
    
```

Orglab

Orglab is a freely distributed component DLL for directly creating or reading Origin Projects (.OPJ) and Origin Window files (.OGG, .OGW and .OGM). An Origin license is not required to use Orglab, and this enables equipment manufacturers and other third-party vendors to save their data as Origin file types.

Download for free at: originlab.com/Orglab



The Origin Viewer is a freely distributed stand-alone application created using the Orglab component DLL. The Viewer allows you to view Origin Project files on computers that do not have Origin installed.

Download the Viewer for free: originlab.com/Viewer

User Case Studies

Using Origin to Analyze and Report on Athlete Performance

Antoine Couturier and Sylvain Dorel, researchers at the Institut National du Sport, de l'Expertise et de la Performance in France, have been using the expanded functionality of the Origin Worksheet to produce clean, professional reports for trainers and athletes to review progress in their training regimens.

The researchers import all of the relevant data from the ergocycle into a custom Origin Analysis Template™. The report sheet then automatically fills with the athlete's information, converts the raw data from the ergocycle to Newtons according to ergocycle calibration, detects cycles and half-cycles and computes mean forces, pedaling rates and powers for each of them. All the data corresponding to forces and power vs. pedaling rate are dynamically plotted and fitted using the Analysis Template™.

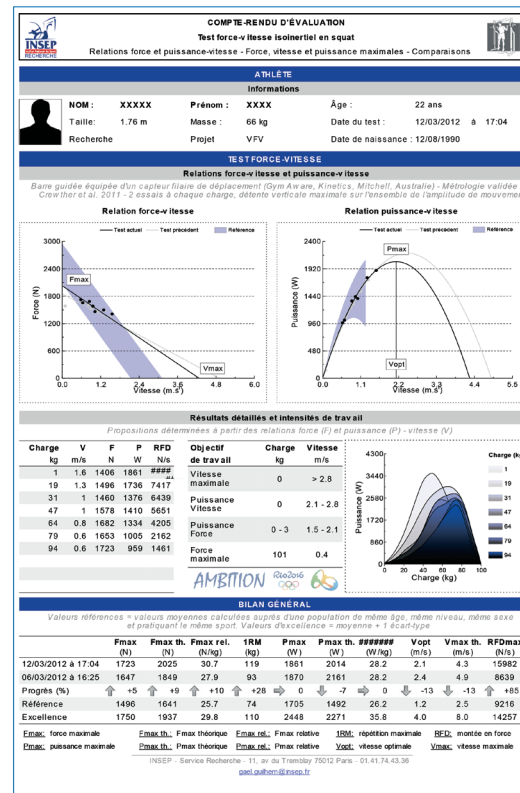

Antoine Couturier says: "Origin is our number one software for visualizing and analyzing experimental data."

Starting from version 8, with the introduction of Analysis Templates™ and custom report, Origin has also become a fantastic tool for scientific coaching of our athletes from the National Institute of Sports, in many disciplines.

Most of the data recorded during the testings are simply drag and dropped into Origin. In a matter of minutes, a database is updated and a complete report is generated for the coaches, including athlete's own progression and comparison to others.

Those unique features have been constantly evolving and allowed us to gain considerable firepower."

Using Origin to Teach Data Analysis and Presentation

Jay Deiner, Ph.D. Assistant Professor of Chemistry NYC College of Technology, City University of New York

Dr. Jay Deiner first started using Origin in 1998 as a graduate student; now, as a professor, he uses it for both his research, and to supplement the advanced chemistry classes he teaches. For example, his students use Origin's analysis features such as peak integration, baseline correction and data picking, to process spectroscopic and chromatographic data. In order to present the final results in an accessible manner they customize their graphs using Origin's comprehensive formatting features.

Jay Deiner says: "I believe that using Origin benefits the students because they learn how to use a sophisticated data analysis program that they may encounter in future work in academic research or in industry. It also enables them to extract much more information from the data they generate. Finally, it helps students understand that much of science is thinking and data analysis. Using Origin benefits me as an instructor because I can teach the class in a more rigorous way."

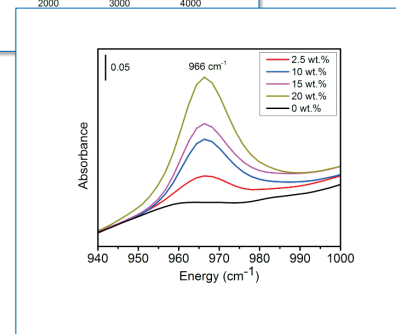
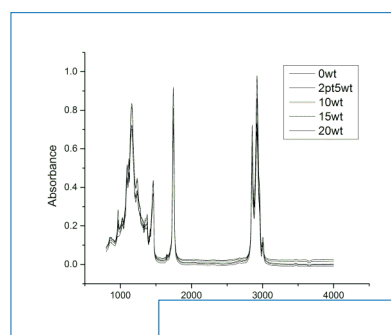

View more user case studies at: originlab.com/UserCaseStudies

Origin C++ for Theoretical and Experimental Projects

Mark Kuzyk, Ph.D., Regents Professor of Physics and Astronomy, Washington State University

Dr. Kuzyk and his graduate students at the WSU Physics department use Origin extensively for both theoretical and experimental research on non-linear optics. The Origin C++ feature is convenient for running Monte Carlo calculations, creating plotting functions and automating the process of importing huge volumes of experimental data from experiments that run nonstop for days.

Mark Kuzyk says: "Origin provides a broad pallet of features, giving the students the ability to do just about anything without a huge learning curve. A few years back, an undergraduate student started working with me on a theoretical research project. I set him up with a copy of Origin, and within 12 months he had become an expert in Origin C++, using it to complete a set of calculations that became the basis of a paper that recently appeared in Physical Review A. By the time he graduated, he had won several prizes in poster and paper competitions."

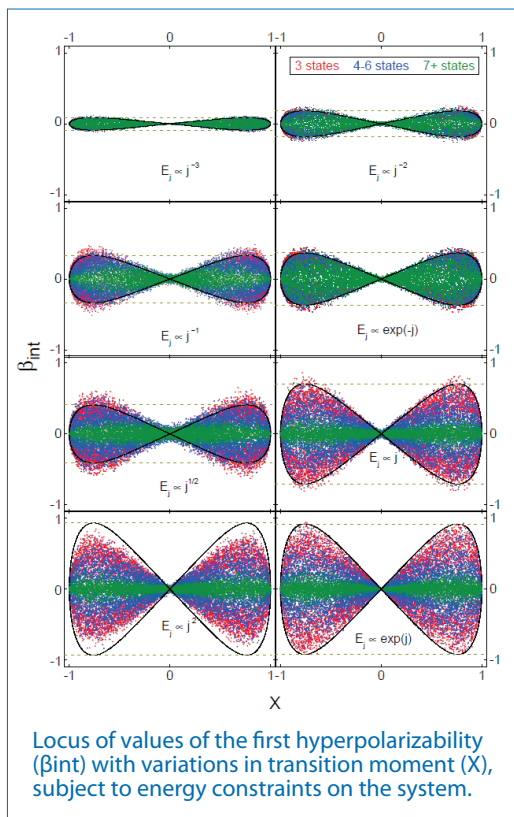

Locus of values of the first hyperpolarizability (β_{int}) with variations in transition moment (X), subject to energy constraints on the system.

Origin as a Financial Reporting Tool

Ariel Fischer, Quantitative Analyst, SpareBank 1 Markets AS, Oslo, Norway

Ariel Fischer and his team are using Origin to construct complex analytical reports that support easy access to financial models and data from different parts of the organization.

Origin met all of their requirements:

- Be flexible, scalable, and easy to modify
- Support automation
- Output publication quality reports
- Handle large amounts of data
- Support different input/output interfaces
- Interface with MATLAB
- Provide aesthetically pleasing reports

This solution has been used to create a credit rating report of 150 Nordic banks. The report is designed to include a summary of financial reports of each bank as well as present and explain the derived credit rating from the underlying credit model. In addition, analysis of aggregated statistics is presented as a function of time. Once new financial data is registered in their data warehouse, an updated credit rating report is created by the click of a button.

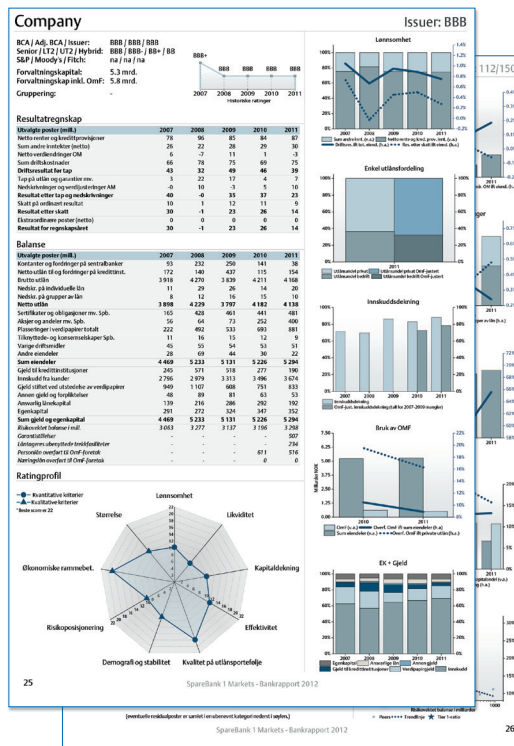

Ariel Fischer says: "The most central Origin feature in this project is the COM-server functionality combined with Origin C and LabTalk, which allows for a seamless integration of Origin with our existing data storage and analysis tools. Additional powerful features of Origin that were utilized include: worksheet queries, animation creation, built-in statistical functions and the import interface. Origin proved to be all-in-all the smoothest way to manage the different elements in the report. The quality of the output is beyond what I have seen in other graphing/analysis-software."

Comparison of Origin and OriginPro

OriginPro provides all of the features of Origin, plus additional analysis tools and capabilities. The following tables provide comparisons between Origin and OriginPro in such areas as curve fitting, peak analysis, statistics, signal analysis, and image handling.*

Curve Fitting		Origin	OriginPro
Linear and Polynomial Fitting	Linear Regression	✓	✓
	Linear Fit with X Error		✓
	Confidence Ellipse for Linear Fit	✓	✓
	Polynomial Regression	✓	✓
	Multiple Linear Regression	✓	✓
	Partial Leverage Plots in Multiple Regression	✓	✓
	Residual Analysis	✓	✓
Nonlinear Fitting	Fitting Multiple Datasets	✓	✓
	Built-in Fitting Function and User-defined Fitting Function	✓	✓
	Parameter Initialization and Derived Parameter Definition	✓	✓
	Bounds and Constraints	✓	✓
	Weighted Fitting	✓	✓
	Fitting with Y Error	✓	✓
	Fitting with X and Y Errors (Orthogonal Regression)		✓
	Global Fit with Parameter Sharing	✓	✓
	Fitting Replica Data	✓	✓
	Residual Analysis	✓	✓
	Fitting with Implicit Functions (Orthogonal Distance Regression)		✓
	Fitting Comparison		✓
	Fit and Rank Multiple Models		✓
	Surface Fitting		✓
	Mathematics		Origin
Simple Mathematics Operations	Simple Mathematics Operations on or Between Datasets	✓	✓
	Set Column or Matrix Values by Using Mathematics Operations	✓	✓
	Normalization	✓	✓
	Interpolation and Extrapolation	1D Interpolation and Extrapolation	✓
Interpolation and Extrapolation of Y From X		✓	✓
Trace Interpolation on XY Data		✓	✓
Trace Interpolation on XYZ Data		✓	✓
2D Interpolation and Extrapolation		✓	✓
	3D Interpolation	✓	✓
Differentiation and Integration	Numerical Differentiation	✓	✓
	1D Numerical Integration	✓	✓
	2D Volume Integration		✓
Area Calculation	Polygon Area	✓	✓
	XYZ Surface Area		✓
	Matrix Surface Area		✓
Others	Average Multiple Curves	✓	✓
	Inverse of a Matrix	✓	✓

Statistics	Origin	OriginPro	
Descriptive Statistics	Basic Descriptive Statistics	✓	✓
	1D and 2D Frequency Counts	✓	✓
	Correlation Coefficient		✓
	Partial Correlation Coefficient		✓
	Cross Tabulation		✓
	Discrete Frequency	✓	✓
	Distribution Fit		✓
	Normality Test (Shapiro-Wilk, Lilliefors, Kolmogorov-Smirnov, Anderson-Darling, D'Agostino-K Squared, Chen-Shapiro)	✓	✓
	Statistics Charts: Histogram, Box Chart, Scatter Matrix, QC Chart, Probability Plot, Q-Q Plot, and Pareto Chart	✓	✓
	Grubbs Test and Q-test to Detect Outliers	✓	✓
Hypothesis Testing	One Sample and Two-Sample t-Test, Pair-Sample t-Test	✓	✓
	Two Sample and Paired-Sample t-Test on Rows		✓
	One Sample and Two Sample Hypothesis Tests for Variance		✓
	One and Two-Proportion Test		✓
Analysis of Variance	One Way ANOVA, Two Way ANOVA	✓	✓
	Three Way ANOVA		✓
	ANOVA: Mean Comparison (Tukey, Bonferroni, Scheffe, Dunn-Sidak, Fisher LSD, Holm-Bonferroni, Holm-Sidak)	✓	✓
	One Way and Two Way Repeated Measure ANOVA		✓
Nonparametric Tests	Sign Test		✓
	Wilcoxon Test for One Sample and Paired Sample		✓
	Two Sample Kolmogorov-Smirnov Test		✓
	Mann-Whitney Test		✓
	Kruskal-Wallis ANOVA		✓
	Mood's Median Test		✓
	Friedman ANOVA		✓
	Multivariate Analysis	Principal Component Analysis	
Cluster Analysis			✓
Discriminant Analysis			✓
Canonical Discriminant Analysis			✓
Partial Least Squares			✓
Survival Analysis	Kaplan-Meier Estimator		✓
	Test Equality of Survival Functions (Log-Rank, Breslow and Tarone-Ware)		✓
	Cox Proportional Hazard Model		✓
	Weibull Fit		✓
Power and Sample Size	One, Two and Paired-Sample t-Test, One Way ANOVA, One and Two-Proportion Test, One and Two-Variance Test		✓
ROC Curve	ROC Curve		✓
Peak Analysis	Origin	OriginPro	
Peak Analysis	Baseline Detection	✓	✓
	Baseline Subtraction	✓	✓
	Peak Finding	✓	✓
	Peak Integration	✓	✓
	Peak Fitting		✓
	Fit Baseline with Peaks		✓
	Fit Individual Peaks with Different Fitting Functions		✓
	Batch Peak Analysis		✓

*To view the complete list of comparison tables go to: originlab.com/ProductComparison

Signal Analysis		Origin	OriginPro
Smoothing and Filtering	Smoothing using Savitzky-Golay Filter, Adjacent Averaging, FFT Filter, and Percentile Filter	✓	✓
	FFT Filters: Low Pass, Low Pass Parabolic, High Pass, Band Pass, Band Block, and Threshold	✓	✓
	IIR Filter Design		✓
Fast Fourier Transform (FFT)	FFT with Basic Options	✓	✓
	2D FFT and 2D FFT Basic Filtering		✓
	Short-Time Fourier Transform (STFT)		✓
Wavelet Analysis	Discrete Wavelet Transform (DWT) and Inverse Discrete Wavelet Transform (IDWT)		✓
	Wavelet Smoothing		✓
	Wavelet Denoising		✓
	Continuous Wavelet Transform (CWT)		✓
	Evaluation of Continuous Wavelet Function		✓
Others	Convolution and Deconvolution	✓	✓
	Coherence		✓
	1D Correlation	✓	✓
	2D Correlation		✓
	Hilbert Transform		✓
	Signal Envelope		✓
	Signal Decimation		✓
Rise and Fall Time Analysis		✓	
Data Manipulation		Origin	OriginPro
Reorganization	Sort Worksheet or Columns	✓	✓
	Stack and Unstack Columns	✓	✓
	Pivot Table	✓	✓
	Split and Append Worksheet	✓	✓
Transformation	Converting XYZ Data to a Matrix	✓	✓
	Transpose Worksheet or Matrix	✓	✓
	Shrink or Expand a Matrix	✓	✓
Extraction and Reduction	Worksheet Query	✓	✓
	Reduce Duplicate X Data	✓	✓
	Reduce Data by Skipping Every N Points	✓	✓
	Reduce Data to Evenly Spaced X	✓	✓
	Reduce XY Data by Group	✓	✓
Others	Find and Replace Numeric and Text Values	✓	✓
	Translate Curve Vertically or Horizontally	✓	✓
	Data Filter for Worksheets	✓	✓
	Select or Hide Columns in Worksheet by Column Label	✓	✓
Gadget		Origin	OriginPro
Gadgets	Surface Integration Gadget		✓
	Global Vertical Cursor Gadget Across Graphs	✓	✓
	Intersect Gadget	✓	✓
	Quick Sigmoidal Fit Gadget	✓	✓
	Cluster Gadget		✓
	Quick Peaks Gadget	✓	✓
	Differentiate and Interpolate Gadget	✓	✓
	Quick Fit Gadget	✓	✓
	Rise Time Gadget		✓
	Integrate, FFT and Statistics Gadget	✓	✓

Apps		Origin	OriginPro	
Fitting	Constrained Multiple Regression		✓	
	Polynomial Surface Fit		✓	
	Sequential Fit		✓	
	Piecewise Fit		✓	
	Enzyme Kinetics		✓	
	General Linear Regression		✓	
	Simple Fit	✓	✓	
	Compare Datasets	✓	✓	
	Compare Linear Fit Parameters and Datasets	✓	✓	
	Mathematics	ODE Solver	✓	✓
Curvature Radius		✓	✓	
Onset Of Slope		✓	✓	
Tangent		✓	✓	
Tafel Extrapolation		✓	✓	
Distance Between Two Points		✓	✓	
Level Crossing		✓	✓	
Signal Processing		Simple pCLAMP Analyzer		✓
	Time-Frequency Analysis		✓	
	Fourier Self-Deconvolution		✓	
	White Noise	✓	✓	
	Statistics	Simple Time Series Analysis		✓
Logistic Regression			✓	
Principal Component Analysis for Spectroscopy			✓	
Advanced Principal Component Analysis			✓	
Hotelling's T-squared Test			✓	
Monte Carlo Simulation			✓	
Probability Distribution Calculator			✓	
Hurst Exponent		✓	✓	
Customizing Graph		Color Editor	✓	✓
		LaTeX	✓	✓
	Maps Online	✓	✓	
	Import Shapefile	✓	✓	
	Colormap for Map Data	✓	✓	
	Layer Stack Manager	✓	✓	
Graphing	Means Plot		✓	
	3D Stacked Histograms		✓	
	3D Confidence Ellipsoid		✓	
	Image Stack Profile		✓	
	Heat Map with Dendrogram		✓	
	Manhattan Plot for GWAS (Genome-Wide Association Studies)	✓	✓	
	3D Wall Profile	✓	✓	
	Plot Submatrix	✓	✓	
	Log Histogram	✓	✓	
	Zoomed Inset	✓	✓	
	Treemap Plot	✓	✓	
	Z Profiler	✓	✓	
	Volcano Plot	✓	✓	
Polyline Profiles	✓	✓		
Import and Export	HDF5 Browser	✓	✓	
	Import Tektronix WFM Files	✓	✓	
	Agilent MS Reader	✓	✓	
	Send Graphs to Word	✓	✓	

Note: New Apps are released frequently. Please visit originlab.com/Apps for the most up-to-date list.

Key Features by Version

Use the following tables to check what new features have been added to Origin, compared to your version.**

Project Management	2017	2016	2015	9.*	8.*
Graph Preview, Comments Tooltip in Project Explorer	✓	✓	✓		
Find String anywhere in Project	✓	✓	✓		
Password Protection for Project/ Worksheet/Files, and Audit Log of Project Save with Optional Password Protection	✓	✓	+	+	✓
Add Comment to Origin Window/Folder	✓	✓	+	✓	✓
Project Explorer(PE) to Help Organize Origin Data	✓	✓	+	✓	+
Batch Processing	2017	2016	2015	9.*	8.*
Smart Plotting with Cloneable Graph Templates	✓	✓			
Clone Workbook/Worksheet during Import for Batch Processing	✓	✓			
Word Template for Report Creation in Batch Process	✓	✓			
Batch Plotting - Duplicate Graphs Using Data from Different Sheets	✓	+	+	✓	
Generate Gadget Output for All Data Plots in the Graph	✓	✓	✓	✓	
Copy & Paste Fitting Operation, Copy & Paste Formula and Labels between Columns	✓	✓	✓	✓	
Repeat Analysis on All Plots in Graph or All Columns in Worksheet	✓	✓	✓	✓	✓
Batch Processing with Summary Report Using Analysis Templates™	✓	+	✓	✓	✓
Batch Peak Fitting of Multiple Datasets Using Peak Analyzer Theme	✓	+	PRO	PRO	PRO
Ease of Use	2017	2016	2015	9.*	8.*
Origin Central Dialog which Help User to Get Start from Origin	✓				
New Plot Menu with Large Icons	✓				
Better Color Control to Pick more Colors and Define Custom Colors	+	✓			
Object Manager to Easily Turn On/Off Plots and Layers	+	✓			
Apps Gallery for Managing Apps Installed from File Exchange	✓	✓			
Collapsible Menus and Context Menus	✓	✓	✓		
F(x) Column Label Row for Column Formula	✓	✓	+		
Set Multiple Column Values	✓	✓	✓		
Copy, Paste and Apply Graph Format and Theme	+	✓	+	✓	✓
Analysis Templates™ with Custom Report Sheets for Repeat Analysis	✓	✓	✓	✓	✓
Consolidated Reports with Collapsible Tables	✓	✓	✓	✓	✓
Save Analysis Dialog Settings as Theme for Future Use	✓	✓	✓	✓	✓
Recalculation of Results on Data or Parameter Change	✓	✓	✓	✓	✓

Graph Types	2017	2016	2015	9.*	8.*
Teillis Plot	✓				
Line Series, Statistics Bars	✓				
3D Stacked Bars, 100% 3D Stacked Bars with new Bar Shapes	✓				
Interval Plot	✓	✓			
Heat Map	✓	✓	✓		
Column Scatter Plot With or Without Jitter	✓	✓	✓		
Kernel Density Plot	✓	✓	✓		
Grouped Column Plots, Grouped Box Chart	+	+	+	✓	
Variable Column/Bar Width	✓	✓	✓	✓	
100% Stacked Column/Bar Plots, Variable Column/Bar Width	✓	✓	✓	✓	
3D OpenGL Waterfall	✓	+	✓	✓	
3D Ternary Surface	✓	✓	✓	✓	
Piper/Trilinear Diagram	✓	✓	✓	✓	
Marginal Histogram/Box Chart	✓	✓	✓	✓	
3D Surface/Bar Plot From Worksheet XYZ Columns	✓	✓	✓	✓	
3D Bar Plot with Z Error Bars	✓	✓	✓	✓	
3D Parametric Function Plot	✓	✓	✓	✓	
Radar/Spider Chart	✓	✓	✓	✓	✓
2D/3D Function Plot and 2D Parametric Function Plot	✓	✓	✓	✓	✓
Multiple Intersecting Surfaces	✓	✓	✓	✓	+
3D Bar Plot, 3D Vector Plot	✓	✓	✓	+	✓
Image/Contour Profile Plot	✓	✓	+	✓	✓
Scatter Matrix	✓	+	✓	✓	✓
Basic 2D, 3D, and Statistics Graphs	+	+	+	+	✓

**To view the complete list of reasons to upgrade go to: originlab.com/VersionComparison

Graph Customization	2017	2016	2015	9.*	8.*
New Annotation Dialog with More Controls for Object Customization	✓				
More Hatch Patterns, including Geology Patterns	✓				
Multiple Axis Reference line and Recession Bars	✓				
Support More Bar Shapes for 3D Bars	✓				
Skip Weekend and Holidays in Financial Plot	✓	✓			
Text and Legend Improvements: Multi-line Spacing, Annotation Customization, Legend Text Color same as Legend Symbols	✓	✓			
Align Layers at Specified Value, Share Common Scale among Layers	✓	✓			
New Tab-based Axis Dialog with Multi-axis Selection and Easy Navigation	+	✓	✓		
More Customization of Color Scale and Bubble Scale	+	+	✓		
Drag Legend to Multiple Columns, Hide Legend of Hidden Plots, Reverse Order of Legend	✓	✓	✓		
Plot: User Defined Menu to Access Customized Templates	✓	✓	✓	✓	
Smart Labels - Auto Position of Data Labels	✓	✓	✓	✓	
Axis Improvements for 2D and 3D graphs: User Defined Axis Scale Type, Multiple Axis Breaks/Special Tick Labels, More Tick/Tick Labels/Breaks Customization	+	✓	+	✓	
Isometric - Link Axis Length to Scale by X/Y Ratio	✓	+	✓	✓	
More Legend Types: Box Chart Components, Point by Point, Categorical Values	✓	+	✓	✓	
Customized Color/Shape/Interior Increment List for Plot	✓	+	✓	✓	
3D Surface Improvements: Lighting Effect, Mesh, Flatten, Shift	✓	✓	✓	✓	
Zoom and Pan inside Graph Layer	✓	✓	✓		
Flexible Annotation Control on Plot	+	+	✓	✓	✓
Customizable Data Info. Window to Read Coordinates and more	✓	✓	✓	✓	✓
Transparency and Gradient Fill Control in Graphs	✓	✓	✓	✓	✓
Embed and Edit Microsoft Word, Excel and Equation Objects Inside Graphs and Layouts	✓	✓	✓	✓	✓
Non-Linear Z-Axis, and Y- and Z-Value Colormap Support for Waterfall Plots	✓	+	✓	✓	✓
Move, Rotate, Skew and Resize 3D Graphs	✓	✓	✓	✓	✓
Axis Tick Locations Controls	+	✓	✓	✓	+
Box Chart with Box/Whisker/Outliers Controls	+	+	+	✓	✓
Fill Area Under/Between Line Plots	✓	+	+	✓	✓
Polar Plot with Azimuth and Radial Axis Controls	+	✓	✓	✓	✓

Data Management	2017	2016	2015	9.*	8.*
Simpler Spreadsheet Cell Notation for Column Formulas	✓				
Select or Hide Columns in Worksheet by Column Label	✓	✓			
Append Worksheet by Matched Column	✓	✓			
Search & Insert Function and Show Function Syntax Hint in Set Column Values Dialog Box	✓	✓	✓		
Customize Categorical Data Order and Apply it to other Columns	✓	✓	✓		
Append Worksheet Row-wise or Column-wise	✓	✓	✓		
Generate Patterned Data	✓	✓	✓	✓	
Sort Column by Values in Column Label Rows, Reduce Columns	✓	✓	✓	✓	
Lock Filter Condition in those Columns Linked to Source Columns	✓	✓	✓	✓	
Excel-Like Data Filtering	+	✓	✓	✓	
Floating Graphs/Layout in Worksheet	+	✓	✓	✓	
Split a Worksheet into Multiple Worksheets by Number of Columns/Rows, or by Column Label	✓	✓	✓	✓	✓
XYZ Gridding in Linear or Logarithmic Scale	✓	✓	✓	✓	✓
Reduce Each Column in Worksheet by Combining Duplicate Rows	✓	✓	+	✓	✓
Pivot Table	✓	✓	+	+	✓
Stack Columns and Unstack Columns	✓	✓	✓	+	✓
Reduce XY Data by Group, Reduce Data to Evenly Spaced X	✓	✓	✓	PRO	PRO
Reduce Duplicate X Data, Reduce Data by Skipping Every N Points	✓	✓	✓	✓	✓
Worksheet Query (Extract Values from Worksheet)	✓	✓	✓	✓	✓
Miscellaneous	2017	2016	2015	9.*	8.*
Native 64-Bit and 32-Bit Applications	✓	✓	✓	✓	✓
Zoom and Pan on Graphs, Worksheets, Matrices and Layouts	✓	✓	✓	✓	+

8.* is for Origin 8.6, Origin 8.51, Origin 8.5, Origin 8.1 and Origin 8.0

9.* is for Origin 9 and Origin 9.1

+ Feature improved in version

Key Features by Version

Use the following tables to check what new features have been added to Origin, compared to your version.**

Importing	2017	2016	2015	9.*	8.*
More 3rd-Party Import Formats: ISF, SAS, BRUKER OPU	✓	✓			
Script after Import and Column Plot Designation for More Import Routines	✓	✓			
Import SPSS Data Files	✓	✓	✓		
Importing OPJ	✓	✓	✓	✓	
Import Mat File Structure	✓	+	✓	✓	
Specify Channel When Import MDF, NITDM, DIAdem, Prism, pClamp, Matlab Data	✓	✓	✓	✓	
File Import Menu Customization Dialogue	✓	✓	✓	✓	✓
Import TDMS 2009, MZXML and Prism Files	✓	✓	✓	✓	✓
SQL Editor for Database Import	✓	✓	✓	✓	✓
Import Excel, Multi-Line CSV and Binary 2D Array	+	+	+	+	✓
3rd Party Formats Support for pCLAMP 2.0, NI DIAdem/TDM, ETAS MDF, JCAMP-DX, NetCDF, HDF5 etc.	+	+	✓	+	✓
Graphically Construct SQL Queries	✓	✓	✓	✓	✓
ASCII and Binary Import Wizard Provides Visual Feedback during Import	✓	✓	✓	+	✓
Import Images (PNG, GIF, TIF, TGA, PCX, PSD, WMF ect (Convert to Raster))	✓	✓	✓	✓	✓
Drag-and-Drop Data File from Windows Explorer into Origin	✓	✓	✓	✓	✓
Import Wizard Filter for Repeat Import of Similar Data	✓	✓	✓	✓	✓
Exporting & Presentation	2017	2016	2015	9.*	8.*
Send Graph to PowerPoint Improvements: Specify Graph List and Order, Specify Slide Layout and Style	✓	✓			
Creating Movies from Origin Windows using GUI Tool or Script	✓	✓	✓	✓	
Graph Export Supports Transparency for PDF and EPS Format	✓	✓	✓	✓	✓
Export All Graphs to PowerPoint	✓	+	✓	+	✓
Export ASCII Data to Existing File by Appending or Replacing	✓	✓	✓	✓	✓
Slide Show Graphs and Layouts	✓	✓	✓	✓	✓
Export Worksheet as Image, WAV, NI TDM/TDMS File or Multi-Page PDF Document	✓	✓	✓	✓	✓
Graph Export Formats Include: CGM, EPS, TIFF, PDF, JPEG, EMF, PSD, etc.	+	✓	✓	✓	✓

Gadgets	2017	2016	2015	9.*	8.*
Profile Gadget	✓	✓	✓		
Surface Integration Gadget	PRO	PRO	PRO	PRO	
Global Vertical Cursor Gadget Across Graphs	✓	✓	✓	✓	
Intersect Gadget	✓	✓	✓	✓	✓
Cluster Gadget	PRO	+	PRO	PRO	PRO
Integrate, Differentiate and Interpolate Gadget	✓	✓	✓	✓	✓
Quick Peaks Gadget	✓	✓	+	✓	+
Digitizer	✓	✓	✓	+	+
Quick Fit Gadget, Quick Sigmoidal Fit Gadget	✓	✓	✓	✓	✓
Rise Time Gadget	PRO	PRO	PRO	PRO	PRO
FFT Gadget	✓	✓	✓	✓	✓
Statistics Gadget	+	✓	✓	✓	✓
Mathematics	2017	2016	2015	9.*	8.*
Show Polygon Area of Selected Contour Line in Data Display	✓	✓	✓		
Akima Spline in Interpolation	✓	✓	✓	✓	
2D Interpolation and Extrapolation	✓	✓	✓	✓	
Compute Polygon Area	✓	✓	✓	✓	✓
Compute Surface Area and Matrix Area	PRO	PRO	PRO	PRO	PRO
2D Volume Integration	PRO	PRO	PRO	PRO	PRO
3D Interpolation	✓	✓	✓	PRO	PRO
Trace Interpolation on XY Data	PRO	PRO	PRO	PRO	PRO
1D Interpolation and Extrapolation, Interpolation and Extrapolation of Y From X	✓	✓	+	+	✓
Trace Interpolation on XYZ Data	✓	✓	✓	✓	✓
Normalization Across Multiple Columns or Curves	✓	✓	✓	✓	✓
Set Column or Matrix Values by Using Mathematics Operations	+	+	+	+	+

**To view the complete list of reasons to upgrade go to: originlab.com/VersionComparison

Curve Fitting	2017	2016	2015	9.*	8.*
Customize Parameter Table in Graph for LR/PR/NLFit and Peak Fitting	✓	✓			
Zoom on Preview tab of Nonlinear Curve Fit	✓	✓	✓		
Improved Fitting Results: Add Normal Probability Plot of Residuals, Put Residual Plots in a Single Graph	✓	✓	✓		
Fit and Rank All Functions in a Category	PRO	PRO	PRO	PRO	
Orthogonal Regression for Implicit/Explicit Functions	PRO	PRO	PRO	+	
Calculate Standard Error for Derived Parameter	✓	✓	✓	✓	✓
Linear Fit with Support for X Error	PRO	PRO	PRO	+	PRO
Surface Fit with Multiple Peaks	PRO	PRO	PRO	PRO	PRO
New Fitting Function Builder for Fitting Function Creation	✓	✓	✓	✓	✓
Graphical Residual Analysis for Fitting	✓	✓	✓	✓	✓
Find-X/Find-Y Tool for Linear, Polynomial, and Nonlinear Fit	✓	✓	✓	✓	✓
New Find-Z Tool for Nonlinear Surface/Matrix Fit	PRO	PRO	PRO	PRO	PRO
Fitting Comparison	PRO	PRO	PRO	PRO	PRO
Peak Analysis	2017	2016	2015	9.*	8.*
Multiple Peak Fit Tool	✓	✓	✓	✓	✓
Batch Peak Fitting	+	+	PRO	PRO	PRO
Peak Analyzer: Peak Fitting, Fit Baseline with Peaks	PRO	PRO	PRO	PRO	PRO
Peak Analyzer: Peak Integration, Peak Finding, Baseline Detection and Subtraction	✓	+	+	✓	+
Signal Processing	2017	2016	2015	9.*	8.*
LOWESS and LOESS Smoothing	✓	✓	✓	✓	
IIR Filter Design	PRO	PRO	PRO	PRO	
2D FFT Filter, Signal Envelope, Coherence	PRO	PRO	PRO	PRO	PRO
Signal Decimation to Reduce/Resample Data	PRO	PRO	PRO	PRO	PRO
1D FFT, Inverse FFT and 1D FFT Filter	✓	✓	✓	✓	✓
2D FFT, 2D Inverse FFT, Short-Time Fourier Transform (STFT), Hilbert Transform, 2D Correlation	PRO	PRO	PRO	PRO	PRO
Wavelet Analysis	PRO	PRO	PRO	PRO	PRO

Statistics	2017	2016	2015	9.*	8.*
New Statistics: 3-way ANOVA, Partial Correlation, Cross Tabulation	PRO	PRO			
Distribution Fit	PRO	PRO	PRO		
Partial Least Squares Regression	PRO	PRO	PRO	PRO	
One/Two-Proportion Testing	PRO	PRO	PRO	PRO	
Grubbs Test and Q-test to Detect Outliers	✓	✓	✓	+	
Multivariate Analysis: Cluster, Principal Component, Discriminant, etc.	PRO	PRO	+	+	PRO
ROC Curve	PRO	PRO	PRO	PRO	+
Survival Analysis: Kaplan-Meier, Cox Proportional Hazard, Log-Rank, etc.	PRO	PRO	PRO	PRO	PRO
Nonparametric Tests: Mann-Whitney Test, etc.	PRO	PRO	PRO	PRO	+
Power and Sample Size	PRO	PRO	PRO	+	PRO
One- and Two-Way Repeated Measures ANOVA	PRO	+	+	PRO	PRO
Hypothesis Testing	✓	+	+	+	✓
Correlation Coefficient	PRO	PRO	+	PRO	PRO
Normality Test	✓	✓	✓	✓	+
Basic Descriptive Statistics, 1D and 2D Frequency Count, Discrete Frequencies, One/Two-Way ANOVA	+	+	+	✓	✓
Connectivity with Other Application	2017	2016	2015	9.*	8.*
Communicate with Individual Mathematica V8 or Later	✓				
R Console and support for Rserve to exchange data between Origin and R	✓	✓			
MATLAB Console with GUI Support to Transfer Data Between Origin and MATLAB	✓	✓	✓	✓	✓
LabVIEW Connectivity	✓	✓	✓	✓	✓
Automation Server Support	✓	✓	✓	✓	✓
Programming	2017	2016	2015	9.*	8.*
Support for HTML Dialog with Java Script	✓				
Origin C Access to Full NAG Mark 25 Library	✓				
Integrate Python as a Scripting Language in Origin	✓	✓	✓		
Ability to Encrypt OC code	✓	✓	✓		
Code Builder has New Editor Based on Scintilla Code, which Supports Code Folding, etc.	✓	✓	✓	✓	
Generate LabTalk Script Command from Current Dialog Box Settings	✓	✓	✓	✓	✓
X-Function: Easy Creation of Custom Tools with Automatic GUI by X-Function	✓	✓	✓	✓	✓
X-Function: Execute X-Function from LabTalk Script and Menu	✓	✓	✓	✓	✓
Command Window: Auto-Complete Support for Scripting	✓	✓	✓	✓	✓

8.* is for Origin 8.6, Origin 8.51, Origin 8.5, Origin 8.1 and Origin 8.0

9.* is for Origin 9 and Origin 9.1

+ Feature improved in version

Licensing

Licenses Available to all Customers

OriginLab offers a variety of Origin and OriginPro individual and multi-user packages for customers in the commercial, academic, non-profit, and government sectors.

Package	For	Description
Individual	Single user.	Available as Origin or OriginPro. Permanent package. Node-locked (fixed seat, computer-specific) license.
Group	Group of users at your organization.	Available as Origin or OriginPro. Permanent package. Node-locked (fixed seat, computer-specific) licenses, or FlexNet concurrent (floating) licenses.
Site	A large group of users within an organization. A site can be one or more departments at the same physical location (including a research center involving multiple departments), or the entire organization / campus.	Available as Origin or OriginPro. Permanent package. Node-locked (fixed seat, computer-specific) licenses, or FlexNet concurrent (floating) licenses.

Additional Licenses Available to Academic Customers

In addition to the packages mentioned above, OriginLab offers the following specially priced packages for academic customers:

Package	For	Description
Research Lab	Research groups involving a faculty member and multiple post-docs, staff members and students.	Available as Origin or OriginPro. Perpetual or time-limited to one year. Node-locked or Concurrent Network license.
Coursework	Student instruction within classroom.	OriginPro Learning Edition Free for students. One-year OriginPro license provided to instructor. Node-locked license.
Laboratory	Student instruction within laboratory.	OriginPro. Time-limited to one year. Renewal can be synchronized with semester schedule. Concurrent Network license. Additional permanent OriginPro license provided to instructor.
Student Version	Student enrolled in a college or university.	OriginPro. Time-limited to 6-months/1-year.

GSA Pricing

For qualifying government customers, OriginLab offers GSA pricing.



OEM Version

Origin is also available to vendors who want to package it with their own products. The Origin OEM version can be directly bundled with your products or it can be customized to meet your specific data analysis and graphing needs.

Learn more about your license options at: originlab.com/LicensingOptions

Over 500,000 Registered Users Worldwide in:

6,000+ Companies including 120+ Fortune Global 500

6,500+ Colleges & Universities

3,000+ Government Agencies & Research Labs

“Case Western Reserve University distributes Origin to students, faculty and staff via a software download website. Members of the University can download, install and activate Origin at their convenience with no help needed from our technical support staff.”

“We have found the process of implementing Origin on our download site to be easy and pleasant. The Origin installation software was easy to use and our users find the setup and activation process to be trouble free and straightforward. We couldn't be more pleased with the service and support we received from OriginLab.”

Pete Babic, Data Systems Manager, Case Western Reserve University

“The Department of Materials Science and Engineering at the University of Florida strives to produce students who graduate with skills and knowledge for careers or for further education. As part of this mission, we want students in the undergraduate laboratories to use state of the art software, so that they have skills to use the tools they will see in their future endeavors. Origin is a high level, professionally recognized software, and we want our students to learn to use this for preparing data for professional reports, publications, and presentations.”

Nancy Ruzycki, Senior Lecturer, Director of Undergraduate Laboratories, Department of Materials Science and Engineering, University of Florida

“I have been using the OriginPro software in my Instrumental Methods of Analysis class (2nd semester of analytical chemistry). We use it for processing infrared, UV-Vis, GC-MS, and HPLC data.

I chose Origin for several reasons:

- 1) I work with it for research and have found it to be powerful and user friendly.*
- 2) Origin is a software tool that is very common in research labs. It is important for students to become familiar with it.*
- 3) Origin offers a very large variety of options for graphing complicated data in a way that makes it straightforward for the reader/audience to understand.*
- 4) The academic 10-pack lease was affordable.”*

Jay Deiner, Assistant Professor of Chemistry, NYC College of Technology, City University of New York

“In our lab, students learn how to present data in a professional fashion, and how to use fitting for data analysis to find system parameters. These skills should help students in their professional engineering and research careers. For me as an instructor, using Origin is an effective way to present lecture material (in other classes), introduce students to new software that is somewhat exciting for students, and to have students coming to my research lab for undergraduate (and potentially for graduate) research prepared to use Origin (which I use in my research).”

Alexei Grigoriev, Department of Physics and Engineering Physics, University of Tulsa

Product Support

Standard support is available to:

- All registered customers with maintenance. (For most packages, the first year of maintenance is included at the time of purchase.)
- All customers evaluating our products.

Support is available Monday - Friday by phone, e-mail and online chat from 8:30 AM to 6:00 PM EST. Extended support hours from 7:30 PM to 4:00 AM EST are available for online chat and e-mail.

Support resources are also available from the OriginLab website, including video tutorials, FAQs, and a product forum.

"My interaction with the OriginLab Technical Support team was excellent! The team was immediately responsive and very cordial. The team diagnosed and solved the problem immediately. Team members are by far the best in the business."

Ray Huffaker - Professor and Chair, Food and Resource Economics Department, Institute of Food and Agricultural Sciences, University of Florida

"Origin is an extremely powerful software package and their technical support has been very responsive. As a new Origin user it has reduced my learning curve tremendously. Between the online videos and rapid replies to my e-mails I have been extremely pleased."

Nigel Clark - NOVA Chemicals

Note: These opinions are personal opinions and do not imply any statement or endorsement by NOVA Chemicals.

"Great support from the OriginLab team! I quickly reached the correct technical support person, he was able to answer my questions, and he followed-up with an email which included an example project & written explanation. This type of quick, personal support is one of the key reasons I have used Origin for the past 10 years."

Eric Scharin - Zogenix, Inc.

Origin Blog

Read our blog for tips and ideas on using Origin. New entries are added regularly: blog.originlab.com

Training Webinars

Register for our periodic webinars covering graphing and analysis using Origin, or view recordings of past webinars: originlab.com/Webinars

User Forums

Our forums contain more than 20,000 posts. Questions are answered daily by OriginLab staff and by other Origin users: originlab.com/Forum

File Exchange

Origin File Exchange contains over 100 entries including Apps, Tools, Templates, Fitting Functions and Examples, provided by OriginLab and the Origin user community: originlab.com/FileExchange

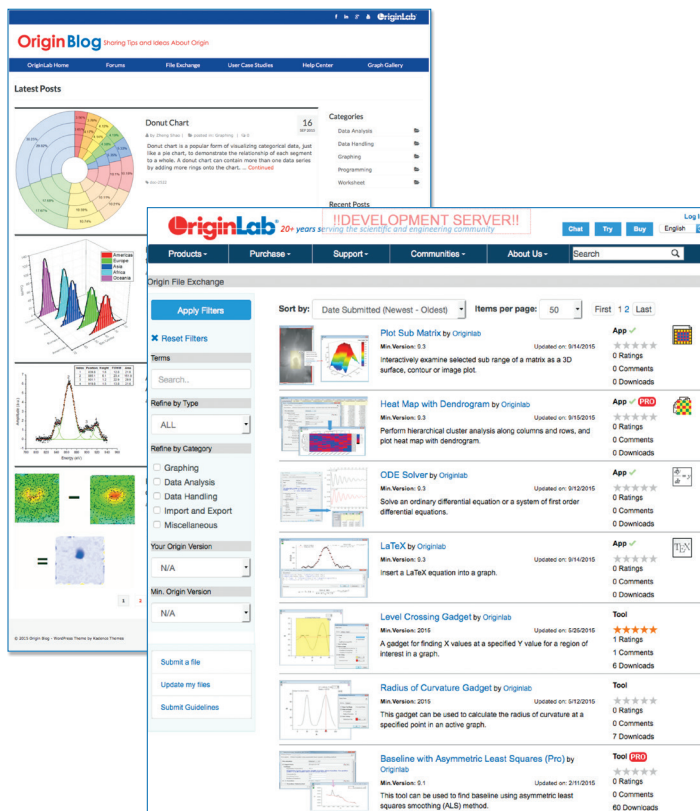

The image displays three screenshots of OriginLab resources. The top screenshot shows the Origin Blog interface with a navigation bar, a 'Latest Posts' section featuring a donut chart, and a 'Categories' list. The middle screenshot shows the OriginLab website homepage with a navigation bar, a search bar, and a 'Products - Purchase - Support - Communities - About Us' menu. The bottom screenshot shows the Origin File Exchange interface with a search bar, a 'Refine by Type' dropdown, and a list of items for sale, including 'Plot Sub Matrix by OriginLab', 'Heat Map with Dendrogram by OriginLab', 'ODE Solver by OriginLab', 'LaTeX by OriginLab', 'Level Crossing Gadget by OriginLab', 'Radius of Curvature Gadget by OriginLab', and 'Baseline with Asymmetric Least Squares (Pro) by OriginLab'.

Visit originlab.com/Support to learn more about our support.

Why Choose OriginLab?

We realize that you have multiple companies and products to choose from for your data analysis and graphing needs. Here are a list of reasons why we think OriginLab is the better choice:

1. Support And Services Beyond The Norm

Our support team members on average have 5+ years of experience helping scientists and engineers with our products. When you contact us, you can rest assured that you will be helped by someone who is very knowledgeable with the product, and is eager to help you.

2. A Well Established Product

Origin and OriginPro are used by over 500,000 scientists and engineers around the world. Year after year, our customer satisfaction survey shows that over 85% of our customers are very happy to recommend Origin to a colleague.

Our R&D team consists of scientists and engineers themselves from a wide variety of disciplines. Each year we publish a new version of Origin and OriginPro, and the features and improvements we introduce are primarily based on customer feedback.

3. A Well Established, And Growing Company

OriginLab has been serving the scientific and engineering community for 25+ years, and is still growing! Our mission is to provide data analysis and graphing software that is flexible and easy-to-use, but at the same time has a range and depth of features that scientists and engineers expect and rely upon for their needs.

OriginLab Services

Maintenance

OriginLab's annual maintenance service includes the following benefits:

- Free Origin and OriginPro upgrades – OriginLab typically publishes one major software release each year.
- Free personal technical support.
- Access to the beta version of our upcoming release.
- Discounts on training and consulting services.

Visit originlab.com/Maintenance to learn more.

Training

Our training programs range from basic training that helps you get started with our products, to advanced training that teaches you how to customize our products to meet your special needs. All training courses are hands-on, providing attendees with the information and expertise to make optimum use of our products.

Visit originlab.com/Training to learn more.

"Bombardier Flight Test Center Engineering have been using Origin for several years. It has served us well. It is always a pleasure working with the OriginLab Team, whether it's to get assistance with special software coding or to train our new employees. As a customer, you make scheduling and conducting the training for our employees, at our facility, so easy. Your support engineers have delivered excellent instruction and technical assistance. Thank you for providing world class support!"

Michael Konicki, Section Chief, Electrical Engineering, Bombardier Flight Test Center

Consulting

OriginLab provides consulting services to customize and enhance Origin to meet your specific analysis and graphing needs. Our Applications engineers will work with you to design and implement your custom Origin solution.

Visit originlab.com/Consulting to learn more.



OriginLab Corporation

One Roundhouse Plaza, Northampton, MA 01060 USA

USA: 1.800.969.7720, Int'l: 1.413.586.2013, Fax: +1.413.585.0126

Email: sales@originlab.com



www.originlab.com